

HARTZELL FAN

OEM Product Guide

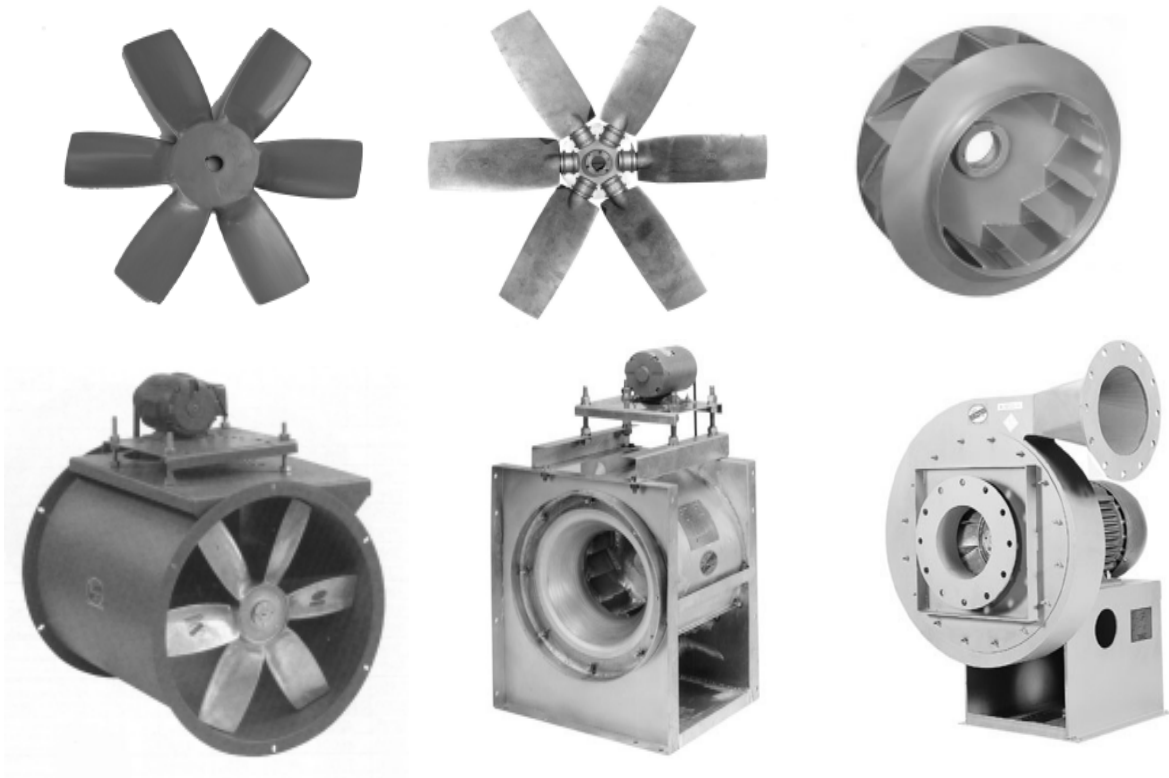

Your Industrial Ventilation Expert
The Better Choice

1-800-336-3267



www.hartzellfan.com

Hartzell Fan “Engineered” Air Movement
Over 75 Years of Innovation, Quality, and Reliability

COMBINE HARTZELL QUALITY...

Airfoil Propellers
Centrifugal Wheels
Complete Fans and Blowers
AMCA Registered Air and Sound Laboratory

...with your quality product
for a **BETTER CHOICE**
to **YOUR Customers**

Our Mission Statement

Our mission is to provide engineered, high quality, and reliable industrial air moving equipment and services.

We are committed to:

- provide prompt and accurate responses to our internal and external customer's needs
- create a cohesive work environment for all employees in which safety and pride are key elements
- the design of innovative and functional products and services
- provide an acceptable return on shareholder equity

Unlimited Applications

- Air circulation
- Aircraft ground circulation
- Automotive
- Biogas/Landfill exhaust
- Cryogenic air circulation
- Combustion Air
- Dust collection
- Fuel cells
- Lumber kilns
- Ovens
- Painting/Spray booths
- Pollution control/WWTP
- Food Processing
- Pneumatic Conveying
- Heat Exchangers
- Drying Equipment

Materials of Construction

Hartzell provides solutions for a broad range of environmental air moving problems with:

- Aluminum
- Fiberglass
- Galvannealed steel
- Steel
- Stainless steel
- Special alloy and special coatings available

Services Available

- Computerized drawings and layout capabilities
- Lab contract testing services
- Custom and modified design services
- Electronic information processing



Aluminum and Steel Propellers and Wheels



Cast Aluminum Propellers
Various sizes and types available in 2, 3, 4, 6, and 8-bladed configurations, including replacement propellers for spray booths



Welded Props
Six blade single camber airfoil, fabricated steel, or stainless steel construction.
Available in Sizes 12" to 60"
Excellent for high temperature steel or stainless steel food grade use



Adjustable Pitch Assemblies
Available in various blade types
Sizes 4" to 14" diameter
Four or six blade assemblies
Ideal for cooling towers, heat exchangers, or as 100% reversible for kilns up to 400 deg. F



Centrifugal Wheels
Various sizes and wheel widths
Backward curved, radial, material, and air handling wheels available
Temperatures to 800 deg. F

Steel Fans



Utility Duct Fan
Sizes 12" to 60"
Perf to 59,250 CFM; SP to 1-1/4"



Fixed Pitch Vaneaxial
Belt or Direct Drive
Sizes 12" to 60"
Perf to 89,000 CFM; SP to 10"



Swing-Out Centrifugals
Sizes 12" to 60"
Class I, II, III
Excellent for spray booth industry

Fiberglass Propellers, Wheels, and Complete Products



Fiberglass Duct Fan - Belt Drive
Sizes 12" to 60"
Perf to 62,200 CFM; SP to 1-1/4"



Fiberglass Duct Axial Fan
Sizes 12" to 60"
Perf to 77,175 CFM; SP to 4-1/2"

Hartzell Fan has the broadest line of AMCA Certified fiberglass fans in the industry. One-piece, solid fiberglass wheels use advanced fibers for highest quality and durability. Each wheel is precision balanced without using metal weights.

Hartzell Fan also pioneered the development of reinforced plastic fans and blowers and manufactures the most complete line of fiberglass products available to the industry, including fans for general and process ventilation applications. Fiberglass construction is recommended where corrosive elements exist in fume and vapor form.



Solid Fiberglass Propellers
2, 4, and 6 blades available
Die formed of individual laminations of fiberglass, cloth mat, plus woven roving



Backward Curved Utility Fan
Sizes 12" to 24"
Perf to 10,300 CFM; SP to 6"



Backward Curved Centrifugal
Sizes 12" to 60"
Perf to 84,000 CFM; SP to 20"



Solid Fiberglass Backward Curved Type FA Centrifugal Wheel
Sizes 12" to 60"
True airfoil for high efficiency, one-piece construction



Special Fans Modified to Meet Your OEM Needs

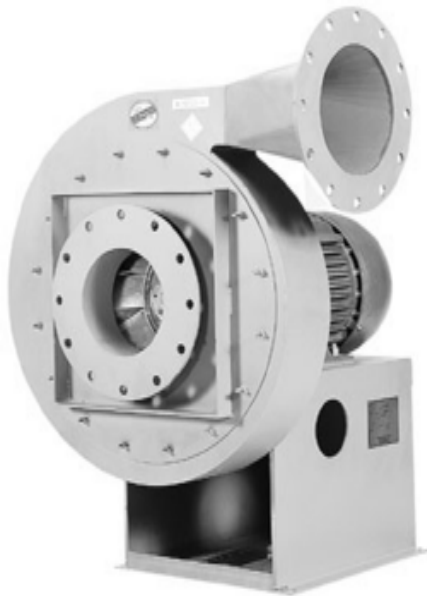

Turbo Pressure Blower
 Sizes 14" to 26"
 Perf. 100 to 5250 CFM, SP to 60"

Common Processes which use the Turbo Pressure Blower are:

- Combustion air for burners and boilers
- High pressure cooling air
- Air pollution control scrubbers
- Air slides and air turns
- Water treatment
- Converting
- Industrial incinerators
- Blow off air knives
- Soil vapor extraction
- Petro-chemical processes
- Fluidized beds
- Material conveying
- Biogas and landfill exhaust
- Fresh air to aircraft while on the ground

Hartzell has a full service Design Engineering Department to adapt our products to suit your dimensional requirements



Series 07T Turbo Pressure Blower
 (Arrangement 1 with sub-base)

Additional OEM Products

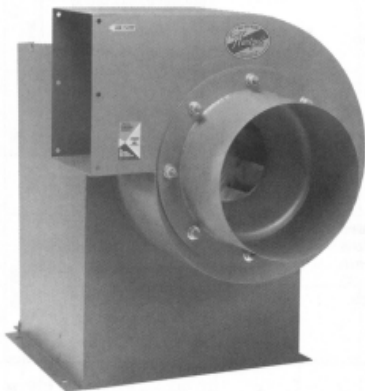

Backward Curved Utility Fan



Square BC Centrifugal Fans



Flange Mounted Industrial Exhausters

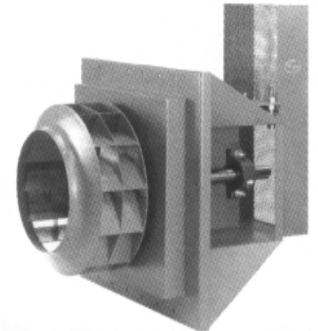

Plug Fan



Gas Fired Make-Up Air Unit

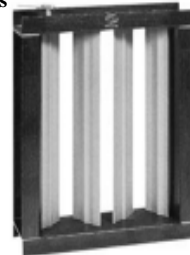

Fiberglass Louvers & Dampers



HartKool Air Circulating Fan

Request Bulletin A-100 for an overview of the complete line of Hartzell equipment available

For the name of your local Hartzell sales rep, call or visit us online:

1-800-336-3267



www.hartzellfan.com