



INSTALLATION, OPERATION,  
& MAINTENANCE  
MANUAL

TABLE OF CONTENTS

<u>TOPIC</u>	<u>PAGE</u>
WARRANTY	2
SAFETY ACCESSORIES WARNING	3
INTRODUCTION	4
SHIPMENT AND RECEIVING	4
HANDLING	5
STORAGE	5
EXTENDED STORAGE	5
INSTALLATION	6
STARTUP	7
MAINTENANCE	8
BEARING LUBRICATION	8
BEARING REPLACEMENT	9
V-BELT DRIVES	10
V-BELT REPLACEMENT	10
FIGURES 1 THRU 4	11
INSTALLING, TENSIONING & CHECKING V-DRIVES	12
MOTORS	13
VIBRATION	13
GREASE LUBRICATION SCHEDULE	14
TROUBLE SHOOTING	15
SPARE PARTS	16

HARTZELL FAN, INC., PIQUA, OH 45356  
Phone# 937-773-8494  
Fax# 937-773-8994

# HARTZELL WARRANTY

## LIMITED WARRANTIES

Hartzell represents to Buyer that any goods to be delivered hereunder will be produced in compliance with the requirements of the Fair Labor Standards Act of 1938 as amended.

Hartzell also warrants to Buyer its goods to be free from defects in workmanship and material under normal use and service for one (1) year after tender of delivery by Hartzell. No warranty extends to future performance of goods and any claims for breach of warranty or otherwise accrues upon tender of delivery.

The foregoing constitute Hartzell's sole and exclusive warranties and are in lieu of all other warranties, whether written, oral, express, implied or statutory.

## LIMITATION OF LIABILITY FOR BREACH OF WARRANTY

Hartzell's obligation for any breach of warranty is limited to repairing or replacing, at its option, without cost to Buyer at its factory any goods which shall, within such a warranty period, be returned to it with transportation charges prepaid, and which its examination shall disclose to its satisfaction to have been defective. Any request for repair or replacement should be directed to Hartzell Fan, Inc., P.O. Box 919, Piqua, Ohio 45356. Hartzell will not pay for any repairs made outside its factory without its prior written consent. This does not apply to any such Hartzell goods which have failed as a result of faulty installation or abuse, or incorrect electrical connections or alterations, made by others, or use under abnormal operating conditions or misapplication of the goods.

## LIMITATION OF LIABILITY

To the extent the above limitation of liability for breach of warranty is not applicable, the liability of Hartzell on any claim of any kind, including negligence, for any loss or damage arising out of or connected with, or resulting from the sale and purchase of the goods or services covered by these Terms and Conditions of Sale or from the performance or breach of any contract pertaining to such sale or purchase or from the design manufacture, sale, delivery, resale, installation, technical direction installation, inspection repair, operation or use of any goods or services covered by these Terms and Conditions shall, in no case exceed the price allocable to the goods or services which gave rise to the claim and shall terminate one year after tender of delivery of said goods or services.

In no event whether as a result of breach of contract, or warranty or alleged negligence, defects, incorrect advice or other causes, shall Hartzell be liable for special or consequential damages, including, but not limited to, loss of profits or revenue, loss of use of the equipment or any associated equipment, cost of substitute equipment, facilities or services, down time costs, or claims of customers of the Buyer for such damages. Hartzell neither assumes nor authorizes any person to assume for it any other liability in connection with the sale of its goods or services.

## NO IMPLIED WARRANTIES OF MERCHANTABILITY OR FITNESS

HARTZELL DOES NOT WARRANT THAT SAID GOODS ARE OF MERCHANTABILITY QUALITY OR THAT THEY ARE FIT FOR ANY PARTICULAR PURPOSE. THERE IS NO IMPLIED WARRANTY OF MERCHANTABILITY AND THERE IS NO IMPLIED WARRANTY OF FITNESS.

# Safety Accessories, Application and Use Warning

The safe installation and operation of equipment supplied by Hartzell Fan, Inc. is the responsibility of the system designer, installer, maintainer, and user. Since the application and use of its equipment can vary greatly, Hartzell Fan, Inc. offers various product types, optional safety accessories, and sound performance data per laboratory tests. Hartzell Fan, Inc. sells its equipment with and without safety accessories, and accordingly, it can supply such safety accessories only upon receipt of an order. The need for safety accessories will frequently depend upon the type of system, fan location and operating procedures being employed. The proper protective safety accessories to meet company standards, local codes, and the requirements of the Occupational Safety and Health Act must be determined by the user since safety requirements may vary depending on the location and application of the equipment. If applicable local conditions, standard, codes or OSHA rules require the addition of the safety accessories, the user should specify and obtain the required safety accessories from Hartzell Fan, Inc. and should not allow the operation of the equipment without them.

Owners, employers, users, and installers should read "RECOMMENDED SAFETY PRACTICES FOR USERS AND INSTALLERS OF INDUSTRIAL AND COMMERCIAL FANS" published by the Air Movement Control Association, Inc., 30 West University Drive, Arlington Heights, Illinois 60004. A copy of this publication is enclosed with each fan shipped from Hartzell Fan, Inc., and is available upon request at Hartzell's office in Piqua, Ohio 45356 (937-773-7411).

Please contact Hartzell Fan, Inc. or your local Hartzell representative for more information on product types, safety accessories, and sound performance estimates.

Remember, the selection of safety accessories and the safe installation, application and operation of equipment supplied by Hartzell Fan, Inc. is **your** responsibility. This warning supersedes all previous editions.

# INSTALLATION, OPERATION, & MAINTENANCE MANUAL

## **INTRODUCTION:**

The purpose of this manual is to aid in the proper installation and operation of fans manufactured by **HARTZELL FAN, INC.** These instructions are intended to supplement good general practices and are not intended to cover detailed instruction procedures, because of the wide variety and types of fans manufactured by **HARTZELL FAN INC.**

*The safe installation and operation of fans is the responsibility of the system designer, installer, maintainer, and user.* From the initial system design through the life of the equipment, safety should be a foremost consideration. Some areas, which require some special attention, include system design, layout and construction, fan performance specifications, foundation and installation details, storage procedures, start-up and commissioning procedures, operation, maintenance, and repair.

Handling and installation should always be performed by experienced and trained personnel who are aware of the hazards associated with rotating equipment. Failure to comply with these practices may result in death or serious bodily injury.

Contact your local Hartzell representative for further assistance.

## **SHIPMENT AND RECEIVING:**

All equipment shipped from Hartzell Fan, Inc. is prepared for shipment in accordance with the requirements of the commercial carrier and/or any special considerations required by the nature of the product.

The Bill of Lading or Express Receipt is an acknowledgement by the Transportation Company of the receipt in GOOD CONDITION, meeting the above requirements for the shipment covered by our invoice.

Our responsibility for this shipment has now ceased. We will not be responsible for loss or damage when you give the Transportation Company a clear receipt. (Standard conditions of sale are F.O.B. factory, unless other terms have been quoted and purchased.)

*Thoroughly inspect all shipments as soon as received.* Keep a record of all equipment received, including inspection details and date of receipt, because of the possibility of partial shipments.

If any of the items called for in this Bill of Lading or Express Receipt are short or damaged, do not accept them until the Freight or Express Agent makes a Damage or Short Shipment Notification on your freight bill or express receipt.

If any concealed loss or damage is discovered, **NOTIFY YOUR FREIGHT OR EXPRESS AGENT AT ONCE** and request an inspection. This is absolutely necessary. Unless you do this, the transportation companies will not entertain any claim for loss or damage. If the agent will not make an inspection, then you should make An Affidavit to the effect that you notified the agent on that particular date and the agent failed to show up. This, with your aforementioned documentation, will properly support your claim.

We will assist you in every possible manner in collecting claims for loss or damage, however this does not make us responsible for collection of claims or replacement of material.

## **HANDLING:**

Handle your equipment with care. Some fans are provided with lifting lugs or holes for easy handling. Others must be handled using nylon straps or well-padded chains and cables, which protect the fan's coating and housing. Spreader bars should be used when lifting large parts.

Axial fans should be lifted by using straps around the fan housing only. **DO NOT LIFT AXIAL FANS BY THE MOTOR, MOTOR BASE, PROP OR FLANGES.**

Centrifugal fans are best lifted using one strap under the fan's scroll and another strap around the bearing base. **DO NOT LIFT CENTRIFUGAL FANS BY THE FAN SHAFT, WHEEL, FLANGES OR INLET SUPPORT.**

Roof ventilators should be lifted by using straps around the fan housing or base only. Spreader bars should also be used to avoid damage to stack caps or hoods. **DO NOT LIFT ROOF VENTILATORS BY THE STACK CAP OR HOOD.**

## **STORAGE:**

If fans are stored for any length of time, they should be stored in a clean, dry location to prevent rust and corrosion. Outdoor storage is not recommended. When outdoor storage is necessary, they should be protected from the elements. Cover the fan inlet and outlet, grease the bearings, and keep motors dry and clean.

## **EXTENDED STORAGE:**

Fans are to be stored in their original containers or equivalent protection and should be kept in a clean, dry, protected warehouse where exercised control over temperature, dust, dew point, shock, and vibration is reasonably maintained.

- A) Temperatures: Between 50 degrees F and 120 degrees F.
- B) Maximum relative humidity of 60%
- C) Shock or vibration: 2 mils maximum to prevent bearings from brinelling.  
Exceeding this limit will require vibration-dampening material under the units.

Motor bearings (and fan bearings on belt drive units) are to be greased at the time of going into extended storage. Motor shaft (and fan shaft on belt drive units) are to be manually rotated every month and additional grease added, purging some of that in the bearing cavity every six (6) months. ***Grease in bearings is to be purged at time of removal from storage, making sure that an ample supply of fresh grease is in each grease cavity. Grease used must be compatible with that already in motor and fan bearings. (See Page 14)***

All motors with space heaters are to have the heaters connected if storage conditions exceed 60% relative humidity and/or if temperatures are below 50 degrees F.

Motor windings should be meggered at the time the equipment is put in storage. At the time of removal from storage, the resistance reading must not have dropped more than 50% from the initial reading. Contact Hartzell Fan, Inc., Warranty and Service Department, if the motor resistance is less than 50% of the initial reading. **NOTE: *Motors in storage may absorb moisture in their windings resulting in a significant loss of insulation resistance. THE APPLICATION OF POWER TO A MOTOR WITH INSUFFICIENT INSULATION RESISTANCE MAY RESULT IN DAMAGE TO THE MOTOR OR OTHER EQUIPMENT.***

Storage records complying with the above requirements should be maintained.

If an extended warranty is desired, contact your local sales representative for charges and details.

## **INSTALLATION:**

*Centrifugal Fans should always be mounted to a flat, level, and rigid structure. The fan base should be shimmed and leveled. Gaps between the foundation and fan base should be grouted. This will ensure permanent alignment and a smooth-running, vibration-free fan, as well as minimize maintenance costs. Failure to properly install the fan base can contribute to excessive vibration.*

Poured concrete foundations are recommended, wherever practical, for floor mounted fans. If vibration isolators are required, they should be installed between the fan and the foundation. Tighten all mounting bolts securely with lock washers and lock nuts.

Fans mounted off ground level should be rigidly mounted to a structural platform and be placed as near as possible to or over, a solid wall or column. Supports for suspended fans must be crossbraced for live load support to prevent side sway.

For roof mounted fans, place the fan curb panel on the roof curb, level, and then anchor the unit to the curb using lag screws, neoprene washers, and flat washers. ***It is recommended that stacks be independently mounted to the roof and use guy wires to prevent side sway. AVOID SUPPORTING A STACK DIRECTLY ON THE FAN FLANGE.***

***In both axial and centrifugal fans, inlet and outlet ducts should be independently supported, and never supported by the fan flanges. Flexible duct connections are recommended. These connections will also minimize noise. The independent mounting of stacks and ducts to the fan flanges will assure that the fan will not be subjected to external forces which may twist or deform fan housing. This also will ensure that the impeller will not strike the housing or cause misalignment of the sheaves and bearings.***

It is recommended that access doors be placed in ductwork just ahead of the fan inlet and just behind the fan outlet for ease of inspection and maintenance. Access doors in a duct system should never be opened with the fan running, to avoid possible equipment damage and personal injury.

***No turns in duct should be closer than two and one half fan diameters away from the inlet or outlet of a fan. Walls or flat surfaces should also not be closer than one fan diameter from the inlet side.***

Branch entries into the main duct should be spaced such that they do not enter directly opposite each other. A maximum of 45 degree angle between main branch and entering branch should be used as a guideline. ***Avoid sudden changes in duct size.*** Use a 14 degree included angle, or less, in reducing a duct to a fan, and not more than 30 degrees included angle to the discharge. Elbow turns should be kept to a centerline radius of at least one and one-half diameters of the duct.

Electrical connections for the fan motor must be connected by a qualified electrician, conforming to the National Electrical code and local codes and practices. When making electrical connections, the motor must be connected following electrical characteristics as indicated by the motor nameplate, and adhere to the wiring diagram on the motor nameplate or in the motor terminal box. ***Motors may fail immediately if improperly connected.*** It is also recommended that an overload device to protect the motor be installed between the current supply and the motor. Recommended tolerances for overload devices should be plus 10 % of the motor full load amperage rating, including the allowance for the motor service factor.

***NOTE: It is common for motors to draw several times full load amperage during startup, for approximately fifteen seconds. Larger sized fans may require twenty seconds or longer.***

## **STARTUP:**

Lock out the primary and all secondary power sources.

A complete inspection should be made of all ductwork and the fan interior. Make certain there is no foreign material, which can be drawn into or blown through the fan or ductwork. Appropriate protective measures and safety practices should be observed when entering or working within these areas. These measures may include the use of goggles, respirators, or other personal protective devices.

Make sure the foundation or mounting arrangement and the duct connections are adequately designed and installed per drawings and in accordance with recognized acceptable engineering practices.

Check and tighten all bolts, fasteners, and set screws as necessary. **NOTE: Forces encountered during shipment, handling and rigging can disturb factory settings.**

Check the fan assembly and bearings for proper grounding to prevent static electrical discharge. **NOTE: Especially important when using FRP fans.**

Ensure power and drive components such as motor starter, variable frequency drive, or hydraulic power unit are properly sized, matched, and connected to the fan.

Check bearings for recommended lubricant and lubrication amount.

Clearance should be checked between the impeller and fan housing. Spin the impeller to determine whether it rotates freely, without hitting anything, and is not grossly out of balance. **NOTE: Prior to shipment, all fans have been thoroughly inspected and have passed stringent operation and balance test.**

Inspect impeller for proper rotation for fan design. Arrows to show direction of rotation and airflow are attached to the fan housings.

Check alignment of drives and all other components.

Check the belt drive for proper sheave selection and installation and make sure the sheaves are not reversed (excessive speeds could develop).

Check for recommended belt tension.

Properly secure all safety guards.

Assure that all appropriate warnings have been put in place.

Secure all access doors to the fan and ductwork.

Restore power and momentarily energize the fan to check the direction of rotation. Listen as the fan coasts to a stop for any unusual noise, identify the source, and take corrective action as necessary.

Switch on the electrical supply and allow the fan to reach full speed. Check carefully for: (1) Excessive vibration (2) Unusual noise (3) Proper belt alignment and tension (4) Proper lubrication (5) Proper amperage, voltage, or power values. If any problem is indicated, **SWITCH OFF IMMEDIATELY.**

Lock out power supply. Secure the fan impeller if there is a potential for windmilling. Check carefully for cause of the trouble, correct as necessary, and repeat check list procedure. ( Ref. Page 15 Trouble shooting chart)

**NOTE: The fan should not need balancing, as it was balanced at the factory to be within stringent vibration levels before shipment. However, there are several things that may cause vibration, such as rough handling in shipment and erection, weak foundations, and alignments. It is recommended that the vibration levels be checked with a vibration analyzer to verify that the vibration is within levels recommended later in this manual. (See Page 13, Table 1.)**

Even if the fan appears to be operating satisfactorily, shut it down after a brief period, lock out the power supply, and recheck startup procedures, as the initial start-up may have loosened the bolts, fasteners, and set screws.

## STARTUP CONT:

The fan may now be put into operation, however during the first eight hours of operation, it should be closely observed and checked for excessive vibration and noise. At this time checks should be made of motor input current and motor and bearing temperatures to ensure that they do not exceed manufacture's recommendations.

After eight hours of operation, the fan should be shut down and the power locked out. Recheck startup procedures and adjust, as necessary.

After twenty-four hours of satisfactory operation, the fan should be shut down (locked out) and the drive belt tension should be readjusted to recommended tension. (See Page 12) **NOTE: ( It is normal for belt drive fans to squeal briefly during startup.)**

## MAINTENANCE:

Periodic inspection of all the fan parts is the key to good maintenance and trouble-free fan operation. Frequency of inspection must be determined by the user and is dependent upon the severity of the application. Prepare a maintenance schedule and make sure it is strictly adhered to.

## **NEVER SERVICE OR ADJUST ROTATING EQUIPMENT WHILE IT IS IN OPERATION. LOCK OUT THE POWER SOURCE BEFORE PERFORMING MAINTENANCE.**

Regular fan maintenance should include the following:

- 1) Check the fan impeller for any buildup of foreign material or wear from abrasion. Both can cause excessive vibration which will lead to damage of the impeller and other fan components. Replace the impeller if excessive wear is noticed. Carefully clean the impeller of any foreign material.
- 2) Check V-belt drives for proper alignment, tension, and excessive wear.
- 3) Lubricate the fan and motor bearings.
- 4) Consult the trouble shooting guide for excessive vibration or noise, insufficient performance, or when the fan does not operate. (See Page 15 Trouble shooting chart)
- 5) Tighten all bolts and setscrews.

## BEARINGS AND LUBRICATION:

All Hartzell belt drive fan bearings are heavy duty; self-aligning ball or roller type, depending on the fan size, motor horsepower, and performance, and are relubricable for continuous service.

Selection of the correct bearing grease and greasing intervals depends on several things. Extreme high or low temperatures, dirty or damp surroundings, and excessive vibration exceeding the "fair" levels in Table 1 are all things that will require more frequent greasing or special greases. ( Refer to Page 14 for recommended greases and greasing intervals.)

The motor bearings and the fan bearings on the belt drive fans should be greased at regular intervals. Motor manufacturers' greasing instructions and recommendations should be followed closely. Avoid the use of a pressure greasing system which tends to fill the bearing chamber completely. Do not overgrease. Use only 1 or 2 shots with a hand gun in most cases. Maximum hand gun rating 40 P.S.I. Rotate bearings during lubrication where good safety practice permits. **NOTE:** On motors with non-regreasable sealed bearings, no lubrication is required for the life of the bearings.

The most frequent cause of bearing failure is not greasing often enough, using incompatible greases or excessive belt tension. Excessive vibration, especially if the bearing is not rotating, will also cause bearings to fail. Bearings must also be protected from water and moisture to avoid internal corrosion.

**NOTE: It is typical for some anti friction bearings to exhibit a running surface temperature in excess of 140 deg. F. This surface will be too hot to touch, but is not cause for alarm.**

## **BEARING REPLACEMENT:**

Fan bearings on belt drive fans should not need to be replaced for many years if the above recommendations are strictly adhered to. However, use the following procedure when bearing replacement is necessary.

1. Lock out power source.
2. Gain access to the fan bearings. On duct, ductaxial, and vaneaxial fans, the fan probably will have to be removed from the duct system. Remove the bearing cover, if any.
3. Loosen the belts by shifting the motor.
4. Remove the impeller and disconnect the lube tubes.
5. Remove the shaft and bearing assembly. Note the position of the bearings' shims.
6. Measure the location of the bearing to the impeller end of the shaft and the bearing spacing.
7. Loosen all bearing/shaft setscrews or other locking device.
8. Remove bearings (may have to be pressed off the shaft).
9. Polish the shaft with fine emery paper (240 Grit or finer) and file the setscrew dimples smooth.
10. Install new bearings on the shaft, making sure that the collars are together, (i.e., facing each other on the shaft) and set screws are in line with each other. Lightly seat one setscrew on each bearing to hold in the approximate position from #5) above.
11. Mount the shaft/bearing assembly in the fan, on shims, with bolts. Do not tighten yet. Just snug up. Loosen setscrews.
12. Center the shaft in the housing (both ends) as closely as possible and shim where necessary. The fan impeller may need to be temporarily installed to get its clearances equal.
13. Tighten the bearing mounting bolts.
14. With a soft-faced mallet, tap the shaft between the bearings while turning the shaft by hand to seat the bearing races. The shaft must turn freely. Tighten all bearing setscrews. Spin the shaft again. Is it free?
15. Reinstall the lube tubes.
16. While rotating shaft purge bearings with fresh grease (Ref. Page 14).
17. Install bearing cover, impeller, and belts, and adjust the motor to get proper belt tension. Also, make sure that the sheaves are properly aligned. (See V-belt drives , Page 10 & 11).
18. If a new shaft is supplied, then ignore items #6 through #8.

Carefully following this procedure will ensure trouble-free service.

## **V-BELTS DRIVES:**

V-belts on Hartzell belt drive fans are oil, heat, and static resistant type, and oversized for continuous duty. With proper installation and maintenance, years of operating efficiency can be added to the life span of the V-belt drive.

V-belt drives should be completely guarded.

A noisy V-belt indicates the need for attention. V-belt noise can be caused by the slapping of the belts against the drive guard or other obstruction. Check for an improperly installed guard, loose belts, buildup of foreign material in the sheave grooves, or excessive vibration. The cause of excessive vibration should be determined and corrected. **NOTE: *It is normal for belts to squeal briefly at startup.***

Check belt tension often. Ideal tension is the tension at which the belt will not slip under peak load conditions. Over-tensioning shortens belt and bearing life. Keep belts free from foreign material which may cause slipping. The use of belt dressing is not recommended. (See Page 12 for recommended tensioning.)

Inspect sheaves often. Keep all sheaves' grooves smooth and uniform. Burrs and rough spots along the sheave rim can damage belts. Dust, oil, and other foreign matter can lead to pitting and rust, and should be avoided as much as possible. Badly worn grooves or a shiny groove bottom indicates that either the sheave, the belt, or both are badly worn. Replace either or both belts and worn sheaves.

Check sheave alignment. Sheaves that are not aligned properly cause excessive belt wear and sheave wear.

## **V-BELT DRIVE REPLACEMENT:**

Whether you are just installing new belts or a completely new drive, worn bearings, bent shafts, or other components that might cause future problems should be replaced at this time. If installing belts only, check existing sheaves carefully for worn grooves or other damage.

Although alignment is not as critical in V-belt drives as in others, proper alignment is essential to long belt and sheave life.

**NOTE: *Loose belts or misalignment can cause fan vibration.***

First, make sure that drive shafts are parallel. ***The most common causes of misalignment are nonparallel shafts and improperly located sheaves.*** Where shafts are not parallel, belts on one side are drawn tighter and pull more than their share of the load. As a result, these belts wear out faster, requiring the entire set to be replaced before it has given maximum service. If misalignment is in the sheave, belts will enter and leave the grooves at an angle, causing excessive belt and sheave wear. (See Page 11, Figure 1).

Shaft alignment can be checked by measuring the distance between the shafts at three or more locations. If the distances are equal, then the shafts will be parallel.

To check the location of the sheaves on the shaft, a straightedge or a piece of string can be used. If the sheaves are properly lined up, the string will touch them at the points indicated by the arrows (See Page 11, Figure 2). Rotating each sheave a half revolution will determine whether the sheave is wobbly or the shaft is bent. Correct any misalignment.

Always use matched belts and never mix new and used belts on a drive. Always replace belts with the right type of V-belt. Install belts correctly. When belts are forced into the sheave with a screwdriver or other wedge, the outer fabric is often ruptured and cords broken. It is well worth the time to move the driver unit closer so the V-belts can be slipped easily into the sheave groove without damage. Shorten the center distance between the driven and driver sheave so the belts can be put on without the use of force. While the belts are still loose on the drive, rotate the drive until all the slack is on one side. Then increase the center distance until the belts are snug. The drive is now ready for tensioning. Tension the belts as indicated on Page 12. **NOTE: *Never "roll" or "pry" the belts into the sheave grooves.*** This can damage the belt cords and lead to belt turnover, short life, or actual breakage. Moreover, it is both difficult and unsafe to install belts this way. Keep take-up rails, motor base, or other means of center distance adjustment free of dirt, rust, and grit. Lubricate adjusting screws and slide rails from time to time.

Tighten all sheave bolts and setscrews before reconnecting the power. **NOTE: *All sheave bolts, setscrews, and belts should be checked and tightened if necessary after two days of initial operation.***

**IMPORTANT: DO NOT INCREASE THE FAN SPEED BEFORE FIRST CONTACTING THE HARTZELL FACTORY. ARBITRARILY SPEEDING UP THE FAN CAN CAUSE MOTOR OVERLOAD, FAILURE, AND POTENTIAL IMPELLER FAILURE.**

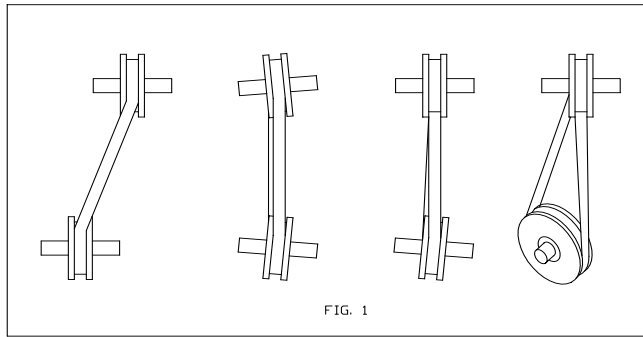

FIG. 1

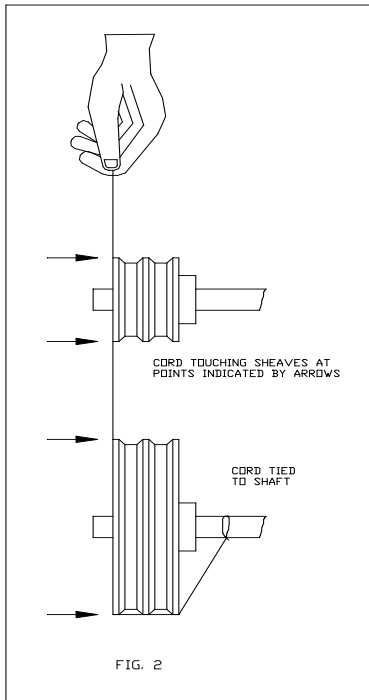

FIG. 2

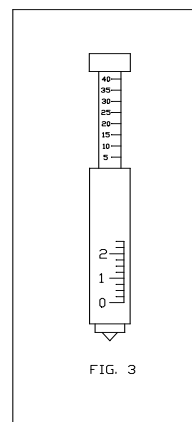

FIG. 3

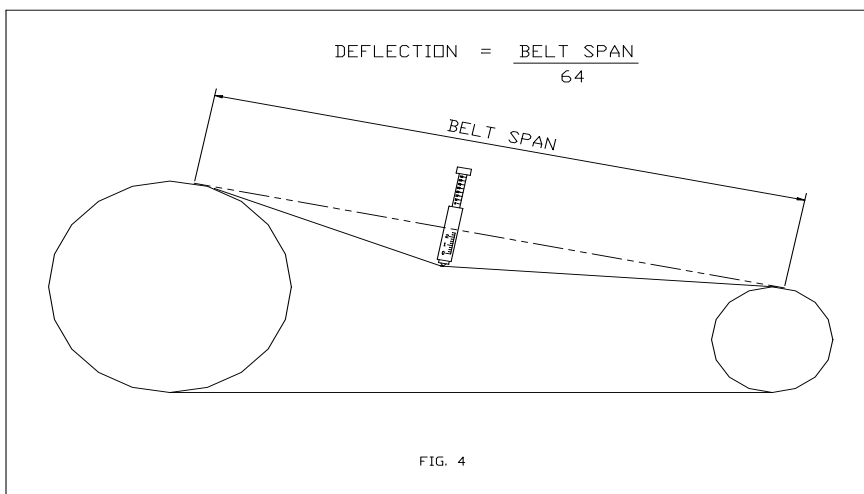

FIG. 4

# INSTALLING, TENSIONING AND CHECKING V-DRIVES

## GENERAL DRIVE TENSIONING GUIDELINES:

1. IDEAL TENSION IS THE TENSION AT WHICH THE BELT WILL NOT SLIP UNDER PEAK LOAD CONDITIONS.
2. OVER TENSIONING SHORTENS BELT AND BEARING LIFE.
3. KEEP BELTS FREE FROM FOREIGN MATERIAL WHICH MAY CAUSE SLIPPING.
4. MAKE PERIODIC V-DRIVE INSPECTION, TENSION WHEN SLIPPING. THE USE OF BELT DRESSING IS NOT RECOMMENDED.
5. BEFORE INSTALLING A NEW SET OF V-BELTS, CHECK THE CONDITION OF THE SHEAVES, DIRTY OR RUSTY SHEAVES IMPAIR THE DRIVES EFFICIENCY AND ABRABE THE BELTS, RESULTING IN PREMATURE FAILURE. ALSO, WORN SHEAVES CAN SHORTEN THE BELT LIFE BY AS MUCH AS 50%.
6. DO NOT USE A NEW OR USED BELT AS REPLACEMENT FOR A UNIT OF A SET. IF A BELT BREAKS A NEW SET OF MATCHED BELTS IS NECESSARY. ALWAYS REPLACE BELTS WITH THE SAME KIND THAT WERE ON THE FAN BEFORE.
7. AFTER PROPERLY TENSIONING THE BELTS, DOUBLE-CHECK TO BE SURE THE SHEAVE GROOVES ARE CORRECTLY ALIGNED, AND THAT ALL SHAFTING IS PARALLEL.

## INSTALLATION AND CHECKING METHODS:

### I. VISUAL METHOD

1. WHEN INSTALLING BELTS, REDUCE THE CENTER DISTANCE SO THAT THE BELTS MAY BE PLACED IN THE SHEAVE GROOVES WITHOUT FORCING. ARRANGE THE BELTS SO THAT THE TOP AND BOTTOM SPANS HAVE ABOUT THE SAME AMOUNT OF SAG. APPLY TENSION TO THE BELTS BY INCREASING THE CENTER DISTANCE UNTIL BELTS ARE SNUG AND HAVE A LIVE SPRINGING ACTION WHEN STRUCK WITH THE HAND.

2. OPERATE THE DRIVE A FEW MINUTES TO SEAT THE BELTS IN THE SHEAVE GROOVES. OBSERVE THE OPERATION OF THE DRIVE UNDER ITS HIGHEST LOAD CONDITIONS (USUALLY STARTING). A SLIGHT BOWING OF THE SLACK SIDE OF THE DRIVE INDICATES ADEQUATE TENSION. EXCESSIVE BOWING OR SLIPPAGE INDICATES INSUFFICIENT TENSION. IF THE SLACK SIDE REMAINS TAUT DURING THE PEAK LOAD, THE DRIVE IS TOO TIGHT.

3. NEW DRIVE TENSION SHOULD BE CHECKED SEVERAL TIMES DURING THE FIRST 24 HOURS OF OPERATION, BY OBSERVING THE SLACK SIDE SPAN.

### II. TENSIONING GAGE METHOD

WHEN A TENSION GAGE IS AVAILABLE AND THE CENTER OF THE BELT SPAN IS ACCESSIBLE, THE FOLLOWING METHOD MAY BE USED. TO DETERMINE THE POUNDS FORCE REQUIRED TO TENSION A DRIVE WITH A BELT TENSIONER, PROCEED AS FOLLOWS:

1. MEASURE THE BELT SPAN AS SHOWN AND CALCULATE THE DEFLECTION INCHES USING THE GIVEN EQUATION. SET LARGE O-RING FOR CALCULATED INCHES OF DEFLECTION.

2. SET SMALL O-RING AT O AND PRESS DOWN THE BELT TENSIONER AT CENTER OF BELT SPAN AS SHOWN.

A. ON A SINGLE BELT DRIVE, DEPRESS BELT TENSIONER UNTIL THE LARGE O-RING IS EVEN WITH BOTTOM OF A STRAIGHT EDGE PLACED ACROSS THE OUTSIDE EDGE OF THE TWO SHEAVES.

B. ON MULTIPLE BELT DRIVE, DEPRESS BELT TENSIONER UNTIL LARGE O-RING IS EVEN WITH THE TOP OF THE NEXT BELT. AVERAGE READINGS FROM ALL BELTS IS THE VALUE TO USE IN THE TABLES BELOW.

3. REMOVE TENSION GAGE AND OBSERVE THE NEW POSITION OF THE SMALL O-RING IS SET AT THE NUMBER OF DEFLECTION POUNDS FOR THE SET NUMBER OF INCHES.

4. COMPARE THIS READING, OR THE AVERAGE OF SEVERAL READINGS IN THE CASE OF MULTIPLE BELTS, TO THE NEW/USED VALUES IN THE TABLES BELOW FOR THE PROPER BELT CROSS SECTION. IF READINGS DO NOT FALL IN THIS RANGE, READJUST THE BELT TENSION AS DESCRIBED IN THE VISUAL METHOD AND REPEAT MEASUREMENT.

### EXAMPLE:

1. BELT SPAN = 1625.6mm AND SMALL SHEAVE IS 203.2mm P.D. WITH COG BELTS.
2. 1625.6mm/64=25.4mm REQUIRED DEFLECTION.
3. SET LARGE O-RING AT 25.4mm ON GAGE INCH SCALE.
4. SET SMALL O-RING AT ZERO ON PLUNGER.
5. PRESS DOWN ON BELTS WITH GAGE UNTIL LARGE O-RING IS EVEN WITH THE NEXT BELT OR A STRAIGHT EDGE, WHICHEVER THE CASE MAY BE. WITH MULTIPLE BELTS, SEVERAL READINGS ARE NEEDED TO GET AN AVERAGE.
6. USE THE POUND FORCE READING OR AVERAGE OF SEVERAL READINGS REQUIRED FOR 25.4mm DEFLECTION IN THE TABLES BELOW.
7. THE "B" BELT TABLE FOR 203.2mm P.D. SMALL SHEAVE SHOULD HAVE A DEFLECTION FORCE BETWEEN 3.311kg AND 4.672kg .
8. INCREASE OR DECREASE THE TENSION ON BELTS UNTIL THE DEFLECTION FORCE IS BETWEEN 3.311kg AND 4.672kg.

( REF. Page 11 )  
( Figures 3 & 4 )

CROSS SECTION	SMALLEST SHEAVE DIA. mm	RPM RANGE	BELT DEFLECTION FORCE			
			STD. BELTS		COG BELTS	
			USED	NEW	USED	NEW
A, AX	76.2-96.5	1000-2500	1.678	2.495	1.860	2.767
		2501-4000	1.270	1.905	1.542	2.268
	96.5-121.9	1000-2500	2.041	3.084	2.268	3.357
		2501-4000	1.724	2.585	1.950	2.903
	127-177.8	1000-2500	2.449	3.629	2.585	3.810
		2501-4000	2.132	3.175	2.313	3.447
	86.4-106.7	860-2500	2.404	3.583	2.223	3.266
2501-4000		2.087	3.084	1.905	2.812	
B, BX	111.8-147.3	860-2500	2.404	3.583	3.221	4.763
		2501-4000	2.041	3.039	3.221	4.128
	147.3-223.5	860-2500	2.858	4.264	3.856	5.715
2501-4000		2.722	4.037	3.311	4.672	
C, CX	177.8-228.6	500-1740	5.216	7.711	6.668	9.888
		1741-3000	4.264	6.260	5.398	7.938
	241.3-406.4	500-1740	6.396	9.525	7.212	10.659
1741-3000		5.670	8.391	6.713	9.798	
D	304.8-406.4	200-850	11.29	16.78	11.34	16.78
		851-1500	9.62	14.20	9.53	14.06
	457.2-508	200-850	13.79	20.50	13.65	20.41
851-1500		11.70	17.24	11.34	17.24	

CROSS SECTION	SMALLEST SHEAVE DIA. mm	RPM RANGE	BELT DEFLECTION FORCE			
			STD. BELTS		COG BELTS	
			USED	NEW	USED	NEW
3V, 3VX	55.9-61.0	1000-2500	N/R	N/R	1.497	2.223
		2501-4000	N/R	N/R	1.270	1.950
	72.4-97.8	1000-2500	1.633	2.313	1.905	2.359
2501-4000		1.361	1.996	1.724	2.540	
	104.6-175.3	1000-2500	2.223	3.311	2.404	3.583
		2501-4000	1.996	2.994	2.223	3.311
	5V, 5VX	111.8-170.2	500-1749	N/R	N/R	4.627
1750-3000			N/R	N/R	3.992	5.987
3001-4000			N/R	N/R	2.540	3.856
	180.3-276.9	500-1740	5.761	8.573	6.713	10.024
		1741-3000	5.080	7.575	6.214	9.117
	299.7-406.4	500-1740	7.031	10.61	7.756	11.57
1741-3000		6.622	9.888	7.620	11.34	
8V	317.5-431.8	200-850	14.97	22.36	N/A	N/A
		851-1500	12.16	18.05	N/A	N/A
	457.2-569	200-850	18.05	26.85	N/A	N/A
851-1500		16.01	23.90	N/A	N/A	

**MOTORS:**

The fundamental principle of electrical maintenance is KEEP THE MOTOR CLEAN AND DRY. This requires periodic inspection of the motor, the frequency of which depends upon the type of motor and the service.

Periodic checks of voltage, frequency, and current of a motor while in operation is recommended. Such checks assure the correctness of frequency and voltage applied to the motor, and yield an indication of the fan load. Comparison of this data with previous data will give an indication of the fan performance. Any serious deviations should be investigated and corrected.

Fractional motors usually have prelubricated sealed bearings with no grease fittings and are lubricated for life.

Lubricate integral horsepower motors per the motor manufacturer's recommendations. Lubrication frequency depends on the motor horsepower, speed, and service. Use compatible greases. (See Page 14). Do not overgrease.

If the motor is totally enclosed fan cooled (TEFC), nonventilated (TENV), or air over (TEAO), it is recommended that the condensation drain plugs be removed. This is not necessary with motors equipped with automatic drains, which should be left in place as received.

**VIBRATION:**

Excessive fan vibration can be caused by many things. **ALL POSSIBLE SOURCES OF THE EXCESSIVE VIBRATION MUST BE CHECKED OUT AND CORRECTIVE ACTION TAKEN IMMEDIATELY TO CORRECT THE PROBLEM.** See the fan trouble-shooting chart (Table 2) for possible causes of excessive fan vibration.

A vibration analyzer will be of great assistance in determining the amount of vibration. The following values give an indication of the fan vibration condition. Vibration readings should be taken on the fan bearings (if possible, on belt drive fans), or motor (on direct drive fans), or on the fan housing of duct, ductaxial, and vaneaxial fans. Horizontal, vertical, and axial readings should be taken.

<b><u>TABLE 1</u></b>				
Vibration displacement in mils, "Double Amplitude"				
<u>FAN RPM</u>	<u>GOOD</u>	<u>FAIR</u>	<u>SLIGHTLY ROUGH</u>	<u>ROUGH</u>
870	1.7	3.3	6.5	above 6.5
1160	1.2	2.5	5.0	above 5.0
1750	.75	1.5	3.5	above 3.5
3450	.50	0.9	2.0	above 2.0

Interpolate for fan speeds other than shown above. The fan should not be operated unless the maximum vibration reading is in at least the "fair" range.

# GREASE LUBRICATION SCHEDULE,

Lubrication guidelines for horizontal shaft, grease lubricated fan, blower or other high speed rotating equipment.  
Lubrication guidelines for vertical shaft -- see note below.

## Link-Belt Ball Bearing Units -- Series 200

Relubrication interval				6 mos	4 mos	2 mos	1 mo
Shaft size range		Amt. of Grease		Operating speed (RPM)			
Inches	MM	Cu. In.	Cu. Cm.				
1/2-1	17-25	0.12	2.0	3200	4800	7200	9600
1 1/16 - 1 7/16	30-35	0.30	4.9	2200	3400	5100	6800
1 1/2 - 1 3/4	40-45	0.45	7.4	1700	2600	4000	5300
1 7/8 - 2 3/4	50-55	0.52	8.5	1400	2100	3200	4300
2 1/4 - 2 7/16	60	0.56	9.2	1300	2000	3000	4000
2 1/2 - 3 (1)	65-75	1.36	22.3	1000	1600	2400	3200
3 1/16 - 3 1/2 (1)	85	2.24	36.7	900	1400	2100	2800
3 9/16 - 4 (1)	100	5.00	81.9	800	1200	1800	2300

## Link-Belt Roller Bearing Units -- Series 22400H & B22500

Relubrication interval				6 mos	4 mos	2 mos	1 mo	2 wks
Shaft size range		Amt. of Grease		Operating speed (RPM)				
Inches	MM	Cu. In.	Cu. Cm.	Up to	Up to	Up to	Up to	Up to
3/4-1	25	0.4	6.4	1400	2200	3400	5000	6800
1 1/16-1 1/4	30	0.5	7.7	1150	1800	2800	4500	5600
1 5/16-1 1/2	35	0.6	9.2	1000	1550	2400	3800	4800
1 9/16-1 3/4	40	0.8	13.1	870	1350	2100	3300	4200
1 13/16 - 2	45-50	0.9	14.6	700	1100	1700	2700	3400
2 1/16-2 1/4	55	1.1	17.9	630	1000	1500	2400	3000
2 5/16-2 1/2	60	1.3	21	580	910	1400	2250	2800
2 9/16 - 3	65-75	2.4	40	460	730	1100	1800	2200
3 1/16-3 1/2	80-85	3.9	64	410	640	1000	1550	2000
3 9/16 - 4	90-100	5.7	94	350	550	850	1350	1700
4 1/16-4 1/2	110-115	6.5	106	300	470	740	1150	1500
4 9/16 - 5	125	10.0	164	280	440	680	1050	1400

## Link-Belt Spherical Roller Bearing Units Series P-LB6800

Relubrication interval				6 mos	4 mos	2 mos	1 mo
Shaft size range		Amt. of Grease		Operating speed (RPM)			
Inches	MM	Cu. In.	Cu. Cm.	Up to	Up to	Up to	Up to
1 7/16 - 1 1/2	40	0.3	4.9	2400	3600	5000	5500
1 11/16 - 1 3/4	45	0.3	5.0	2200	3300	4500	5000
1 15/16 - 2	50	0.4	6.6	2000	3000	4000	4500
2 3/16 - 2 1/4	60	0.8	12.7	1700	2500	3400	3800
2 7/16 - 2 1/2	65	0.8	12.3	1450	2200	3000	3400
2 11/16 - 2 3/4	70	0.9	14.3	1350	2000	2800	3200
2 15/16 - 3	75	1.2	19.7	1300	1900	2600	3000
3 3/16 - 3 1/4	80	1.7	27.4	1200	1800	2400	2700
3 7/16 - 3 1/2	90	2.3	37.7	1100	1650	2200	2300
3 11/16 - 4	100	3.1	50	1000	1500	1950	2100
4 3/16 - 4 1/4	110	4.3	70	900	1350	1850	1900
4 7/16 - 4 1/2	115	5.5	90.1	840	1250	1700	1800
4 15/16 - 5	125	6.4	105	780	1150	1600	1700
Clean and repack intervals				5 yrs	3 yrs	2 yrs	1 yr

## Link-Belt Ball Bearing Units -- Series 300

Relubrication interval				6 mos	4 mos	2 mos	1 mo
Shaft size range		Amt. of Grease		Operating speed (RPM)			
Inches	MM	Cu. In.	Cu. Cm.	Up to	Up to	Up to	Up to
3/4 - 1	20-25	0.3	4.1	2800	4400	6400	8400
1 1/16-1 7/16	30-35	0.7	10.7	2000	3100	4500	6000
1 1/2 - 1 3/4	40-45	1.0	16.4	1500	2400	3500	4600
1 13/16-2 3/16	50-55	1.7	28	1200	2000	2900	3800
2 1/4 - 2 7/16	60	2.1	34	1100	1800	2600	3500
2 11/16-2 15/16	70-75	3.3	54	900	1400	2100	2800
3 - 3 3/16	80	4.5	74	800	1300	2000	2600
3 7/16 - 3 1/2	85	6.6	108	800	1200	1800	2400
3 15/16	100	10	170	700	1100	1600	2100

Lubricate with a premium quality NLGI 2 or 3 multi-purpose ball bearing grease having corrosion inhibitors, anti-oxidant additives and mechanical stability for high speed operation. The grease should also have a minimum base oil viscosity of 500 SUS at 100° F and be suitable to operate continuously at 225° F. Do not use a heavy, long fibered grease.

The bearings on this fan shaft have been greased at the factory for the following application:

- General Purpose (Shell Oil-Shell Alvania EP#2)
- High Temperature (Shell Oil-Aeroshell #22 (-85° F. to 400° F.))
- Low Temperature (Shell Oil-Aeroshell #22 (-85° F. to 400° F.))
- Extreme Moisture (Shell Oil-Shell Alvania EP#2)
- Other: \_\_\_\_\_

These units are prelubricated(except Series P-LB6800) with a multi-purpose Lithium soap grease. When relubricating with greases of different types (especially synthetic soaps or oils), complete flushing is recommended.

The presence of dirt, moisture or chemical fumes around the bearings requires more frequent lubrication. Ambient temperatures below 20° F or above 200° F require special lubricants. Consult the machinery manufacturer for recommendations.

When vibration exceeds 0.15 in./sec., frequent lubrication is required and a need for equipment trim balancing may be indicated.

Fill bearings with lubricant prior to extended shutdown or storage. Rotate the shaft several revolutions each month during idle periods.

(1) It is possible to dislodge the seals on these units if grease is added too fast. It is preferable to use a hand gun or a regulated automatic system

**VERTICAL SHAFTS:** For vertical applications more frequent relubrication is required. The above relubrication interval (and clean and repack interval for the Series P-LB 6800 bearings,) should be reduced by half.

**TABLE 2****FAN TROUBLE-SHOOTING CHART**

<b>PROBLEM</b>	<b>POSSIBLE CAUSES</b>
EXCESSIVE VIBRATION	<ul style="list-style-type: none"> <li>-Accumulation of material on impeller</li> <li>-Worn or corroded impeller</li> <li>-Bent shaft</li> <li>-Impeller or sheaves loose on shaft</li> <li>-Motor out of balance</li> <li>-Impeller out of balance</li> <li>-Sheaves eccentric or out of balance</li> <li>-Bearing or drive misalignment</li> <li>-Mismatched belts</li> <li>-Belts too loose or too tight</li> <li>-Loose or worn bearings</li> <li>-Loose bearing bolts</li> <li>-Loose fan mounting bolts</li> <li>-Weak or resonant foundation</li> <li>-Foundation not flat and level</li> <li>-Structures not crossbraced</li> <li>-System pulsation (DANGER) - Fan operation in a stall</li> <li>-Blades at different angles on adjustable pitch fans</li> </ul>
HORSEPOWER TOO HIGH	<ul style="list-style-type: none"> <li>-Fan speed higher than design</li> <li>-Air density higher than design</li> <li>-Impeller rotating in the wrong direction</li> <li>-Angle set too high in adjustable pitch fans</li> </ul>
AIRFLOW TOO LOW	<ul style="list-style-type: none"> <li>-Impeller rotating in the wrong direction</li> <li>-Fan speed lower than design</li> <li>-Actual system is more restrictive (more resistance to flow) than expected.</li> <li>-Dampers or registers closed</li> <li>-Leaks or obstructions in duct work</li> <li>-Filters or coils are dirty or clogged</li> <li>-Inlet or outlet screens clogged</li> <li>-Restricted fan inlet or outlet</li> <li>-No straight duct at fan outlet</li> <li>-Sharp elbows near fan inlet or outlet</li> <li>-Improperly designed turning vanes</li> </ul>
AIRFLOW TOO MUCH	<ul style="list-style-type: none"> <li>-Actual system is less restrictive (less resistance to flow) than expected</li> <li>-Fan speed higher than design</li> <li>-Filter not in place</li> <li>-Registers, grilles and/or dampers not installed</li> </ul>
FAN DOES NOT OPERATE	<ul style="list-style-type: none"> <li>-Blown fuses</li> <li>-Broken belts</li> <li>-Loose pulleys</li> <li>-Electricity turned off or not wired properly</li> <li>-Wrong voltage</li> <li>-Motor too small and overload protector has broken circuit</li> </ul>

( CONT. )

**TABLE 2 (CONTINUED)**  
**FAN TROUBLE-SHOOTING CHART**

<b>PROBLEM</b>	<b>POSSIBLE CAUSES</b>
EXCESSIVE NOISE	<ul style="list-style-type: none"> <li>-Accumulation of material on impeller</li> <li>-Worn or corroded impeller</li> <li>-Bent shaft</li> <li>-Impeller or sheaves loose on shaft</li> <li>-Impeller hitting housing</li> <li>-Impeller out of balance</li> <li>-Bearing or drive misalignment</li> <li>-Mismatched belts</li> <li>-Belts too loose or too tight</li> <li>-Belts hitting guard</li> <li>-Loose or worn bearings</li> <li>-Belts worn</li> <li>-Belts oily or dirty</li> <li>-Defective or bad bearings</li> <li>-Bearings need lubrication</li> <li>-Loose bearing bolts</li> <li>-Loose fan mounting bolts</li> <li>-System pulsation or surge</li> <li>-Electrical noises</li> <li>-Noise from high velocity air system               <ul style="list-style-type: none"> <li>-Duct work too small</li> <li>-Registers or grilles too small for application</li> </ul> </li> <li>-Fan in stall condition (DANGER)</li> <li>-Rattle of components in high velocity airstream</li> <li>-Leaks in duct work</li> <li>-Vibrating duct work</li> <li>-Vibrating parts not isolated from building</li> </ul>

It is recommended that the users and installers of this equipment familiarize themselves with AMCA publication #201, "Fans and Systems, and publication #202 "Trouble-Shooting", which are published by Air Movement and Control Association, 20 West University Drive, Arlington Heights, Illinois 60004.

**SPARE PARTS:**

Spare parts are not needed for the first year of operation. If spare parts are desired, then it is suggested that a spare motor and impeller be ordered for direct drive fans. For belt drive fans, in addition to the motor and impeller, it is suggested that a spare set of bearings, shaft, sheaves, and belts be ordered.

When ordering spare parts, specify the parts desired, the fan model number, and the fan serial number. Contact your local sales representative for price and delivery.

HARTZELL FAN, INC., PIQUA, OHIO 45356  
Phone# 937-773-8494  
Fax# 937-773-8994