

Fiberglass Radial Blowers

Series 42

Series 43

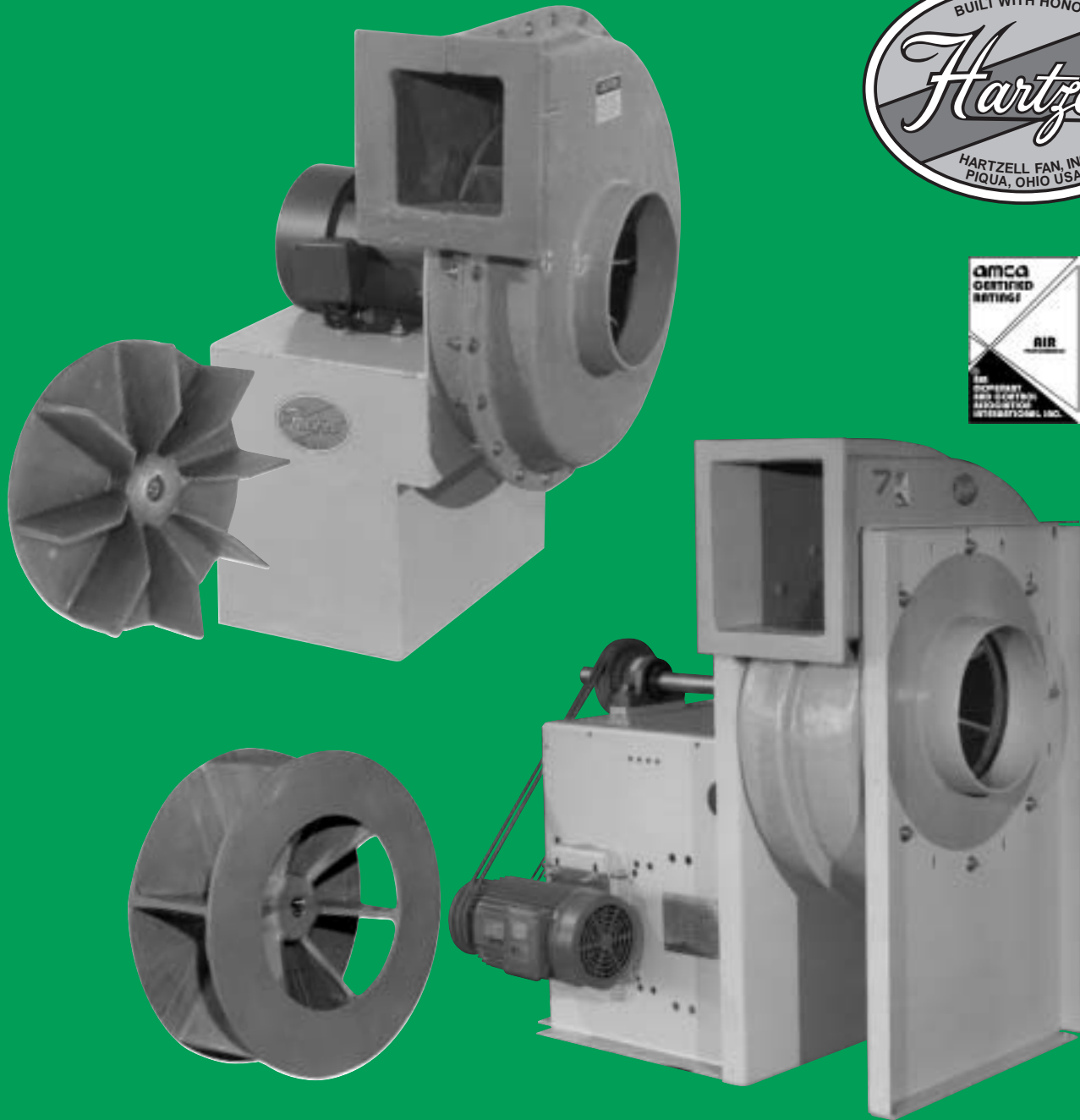

HARTZELL®

Hartzell Fan, Inc., Piqua, Ohio 45356
www.hartzellfan.com

Index

Hartzell Model Code Explanation Page 2
General Construction Features
Centrifugal Fan Arrangements Page 3
Fiberglass Pressure Blower – Series 42 Page 4
Dimensional Drawings – Series 42 Page 5
Performance Data – Series 42 Page 6

Fiberglass Radial Blower – Series 43 Page 7
Dimensional Drawings – Series 43 Page 8
Performance Data – Series 43 Pages 9-11
Temperature/Altitude Applications Page 12
Corrosion Resistance Guide Page 13
Options and Accessories Pages 14-15



Certified Ratings for Air Performance

Hartzell Fan, Inc. certifies that the Series 42 Fiberglass Pressure Blowers, on page 4; and Series 43 Fiberglass Radial Blowers on pages 7 through 11, are licensed to bear the AMCA seal for air performance. The ratings shown are based on tests and procedures performed in accordance with AMCA Publication 211 and comply with the requirements of the AMCA Certified Ratings Program.

Hartzell Model Code Explanation

Fiberglass Fan Selection

The Hartzell Fiberglass Radial Blower performances on the following pages are based on standard air conditions (sea level, 70°F, and 29.92 inches barometric pressure). Performance data does not include drive losses on belt drive units.

When placing your order, be sure to specify the Hartzell Model Code. The following example demonstrates our coding system.

The illustrated Series Number specifies a Hartzell Series 42 Fan. Be sure to include fan model, performance requirements, operating temperature, motor data (enclosure, voltage, mounting position, etc.) and a list of required accessory items. (See pages 14 and 15.)

Contact your local Hartzell Sales Representative for assistance.

Hartzell Model Code

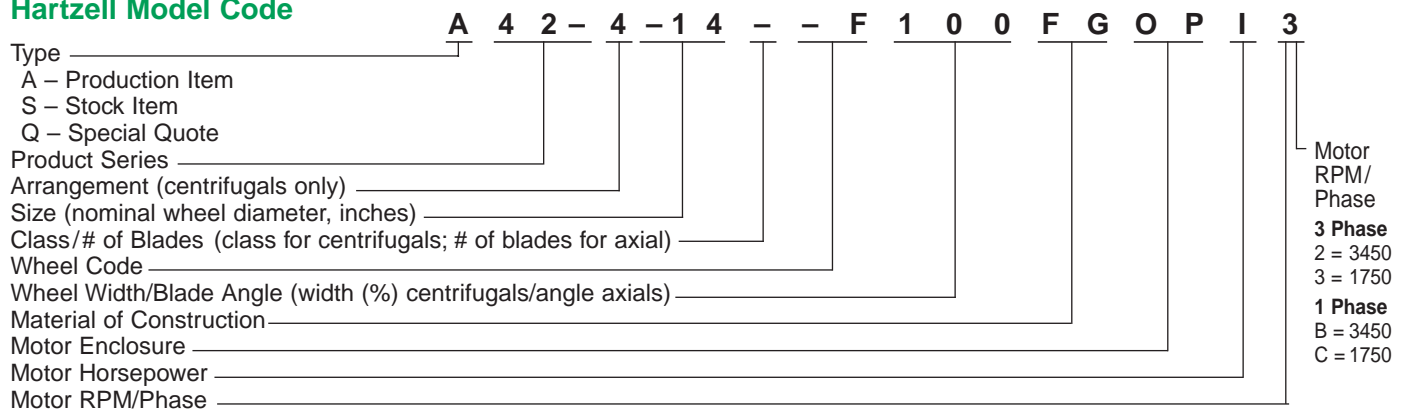

Motor Horsepower

Horsepower	1/4	1/3	1/2	3/4	1	1 1/2	2	3	5	7 1/2	10	15	20	25	30	40	50	60	75	100	125	150	200
Code Letter	D	E	F	G	H	I	J	K	L	M	N	O	P	Q	R	S	T	U	V	W	X	Y	Z

Example:

Assume a needed performance of 800 CFM at 4" SP, standard air. Reading the 14" rating table on page 6, we find a fan RPM of 2220 and brake horsepower (BHP) of 1.20. Required motor horsepower is 1 1/2.

The model code can be constructed as follows: Type will be a production item (code A), product series for the Fiberglass Radial Blower is 42, arrangement is 4 (code 4), size of the wheel is 14",

blade code for this item is F, wheel width is 100% (code 100), material of construction is fiberglass (code FG), motor enclosure is open protected drip proof (code OP), motor horsepower is 1-1/2 (code I), and motor RPM/phase is 1750 (code 3).

Note: All other informational fields must be filled with hyphens/dashes (-) if they are not applicable to the fan being considered.

This bulletin lists Hartzell's complete line of Fiberglass Radial Blowers and accessories. More than 70 Hartzell offices can provide specific performance and installation data to meet your requirements. Call your Hartzell representative for assistance. Visit our website (www.hartzellfan.com) or call toll-free (1-800-336-3267) for the name of your Hartzell representative.



Construction Features

A variety of corrosion problems plague industry today. Fans and blowers made of coated steel or metals such as stainless and monel can handle some problem areas. Please refer to the corrosion resistance table on page 13 of this bulletin. Fiberglass centrifugal blowers can be used in most applications where corrosive elements exist in fume and vapor form. The resistance to corrosive elements is a major advantage, but the physical properties of fiberglass equipment offer these additional advantages:

- Fiberglass equipment is corrosion resistant.
- Fiberglass equipment weighs 25% less than comparable equipment made of carbon steel.
- Fiberglass has an extremely high strength-to-weight ratio, stronger than steel on a per-pound basis.
- Dimensional stability of fiberglass is excellent.
- Fiberglass air moving equipment will not become brittle at low temperatures and at 0°F the laminated fiberglass will be stronger than at room temperature.

Hartzell Fan, Inc. conforms to ASTM D4167-97, Standard Specification for fiber-reinforced plastic fans and blowers, when optional surfacing veil, electrical grounding, and dynamic balancing to ASTM D4167-97 levels, are added to the fan.

The following are standard Hartzell fiberglass construction features:

- Corrosion resistant polyester resin, having a class I flame spread rate of 25 or less is used for all housings. Vinylester resin having a class I flame spread rate of 30 or less is used for all wheels.

- All structural parts in the airstream are fiberglass and resin. All fiberglass surfaces are protected with a minimum 10-mil thickness of chemical, flame, and ultraviolet resistant resin.
- Shafts are turned, ground, polished, and keyed at both ends with a fiberglass sleeve in the airstream. Shafts are sized to operate well below critical speed. 304 or 316 Stainless steel or monel shafting is available as an option at extra cost.
- Internal hardware (airstream) is Type 304 stainless steel. All internal hardware (airstream) is encapsulated. All external hardware (out of airstream) is zinc plated as standard. Where metal is subject to attack by the corrosive elements being handled, all metal parts can be resin-coated after assembly.
- A fiberglass and neoprene shaft seal is placed where the shaft leaves the housing along with a neoprene shaft slinger between the seal and wheel on belt drive units. (Seal is not gas tight.)
- Bearings on belt drive units are heavy duty, deep row radial ball or double row spherical roller type self-aligning and shielded in cast iron housings. Long inner races insure even load distribution, providing a high radial and thrust load capacity. Bearings are relubricable for continuous service with lubrication tubes extended to the exterior of fan base as necessary.
- V-Belt Drives are oversized for long life and continuous duty as standard. Fixed pitch or variable pitch drives are available upon request. Belts are oil, heat, and static resistant type.

Centrifugal Fan Arrangements

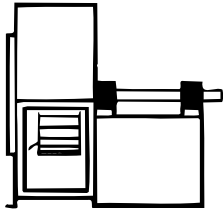
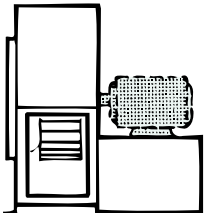
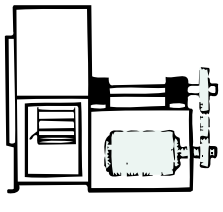
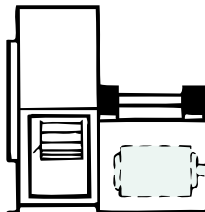
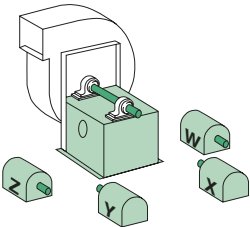
<p>Arrangement 1 Unit furnished with shaft and bearings, less motor and drive. Designed to be driven by a separately mounted motor. Impeller is overhung – two bearings on base. Temperature limitations: 250°F Series 42 or 43.</p> 	<p>Arrangement 4 Direct drive packaged unit, wheel is overhung and attached to the shaft of the electric motor. No bearings on fan. Temperature limitations: 200°F Series 42 only.</p> 
<p>Arrangement 9 Belt drive configuration with motor mounted on outside of bearing base support. Packaged unit, wheel is overhung, slide rail motor base permits easy adjustment of belt tension. Available on either left or right hand side of base (when facing drive end of shaft). Temperature limitations: 250°F Series 43 only.</p> 	<p>Arrangement 10 Belt drive configuration with motor mounted inside base. Packaged unit, wheel is overhung. Temperature limitations: 250°F Series 42 or 43.</p> 
<p>Motor Position Designation Motor position designation is necessary when ordering the following for Arrangement 1 fans –</p> <ol style="list-style-type: none"> 1 - V Belt Drive. 2 - Vibration Bases. 3 - Belt Guards. <p>Note: Location of motor is determined by facing the drive side of the fan and designating the motor position by letters W, X, Y or Z.</p> 	

Adapted from AMCA Standard 99-2404-03, *Drive Arrangements for Centrifugal Fans*, and AMCA Standard 99-2407-03, *Motor Positions for Belt or Chain Drive Centrifugal Fans*, with written permission from Air Movement and Control Association International, Inc.



Fiberglass Pressure Blower

Series 42



Arrangement 4



Hartzell Fan, Inc. certifies that the Series 42, Fiberglass Pressure Blower, shown hereon is licensed to bear the AMCA Seal. The ratings shown are based on tests and procedures performed in accordance with AMCA Publication 211 and comply with the requirements of the AMCA Certified Ratings Program.



**Type F Wheel
(Series 42)**

Blowers available in SWSI only

Particularly suited for lab hood installations, the corrosive resistant direct drive pressure blower moves air at static pressures up to 12". The housing is constructed with a special corrosion resistant polyester resin having a Class I flame spread rate of 25 or less. The wheel is made using a special corrosion resistant vinylester resin having a Class I flame spread rate of 30 or less. There are no metal parts exposed in the airstream. All internal hardware is 300 series stainless steel encapsulated.

Features

- **Sizes** – 10", 12" and 14" wheel diameters.
- **Arrangement** – available in Arrangements 4 or 10.
- **Temperature Limitations** – suitable for temperatures up to 200° F. See Table 3, page 12 for maximum safe speed correction factors at high temperatures.
- **FRP Materials** – solid fiberglass wheel molded with Dow Derakane 510-A vinylester resin. Other standard FRP components constructed of fiberglass and Ashland Hetrion 693 resin. See Corrosion Resistance Guide on page 13 for resin characteristics. Other resins are available.
- **Rotation** – **clockwise rotation standard**. Counterclockwise rotation available.
- **Discharges** – available discharges shown on page 5. **Rotatable in field.**
- **Easy installation and maintenance** – motors are readily accessible for ease in wiring, installation, adjustment and lubrication.
- **Wheel** – flat blade radial design of one-piece construction, die formed of individual laminations of fiberglass. **Wheel Type F.**
- **Motors** – are available to your specifications, mounted and test run at the factory prior to shipment.
- **Drive Assembly (Belt Drive Fans)** – belts are oil, heat and static resistant type, oversized for continuous duty. Shafts are turned, ground and polished, keyed at both ends.
- **Bearings (Belt Drive Fans)** – heavy-duty, self-aligning, pillow block bearings are standard.
- **Shafts (Belt Drive Fans)** – turned, ground and polished. Fiberglass enclosed in the airstream. Stainless steel (304 or 316) or monel shafting is available as an option at extra cost.
- **Shaft Seal (Belt Drive Fans)** – a fiberglass and neoprene shaft seal is placed where the shaft leaves the housing along with a neoprene shaft slinger between the seal and wheel on belt drive units. Seal is not gas tight.
- **Flanged outlets are standard**. Inlet flanges are optional. Drilling of flanges is optional.
- **Bases** – heavy gauge hot rolled steel, epoxy coated.
- **All units are test run and electronically balanced** before shipment.
- **Accessories** – See pages 14 and 15.



Series 42 - Arrangement 10

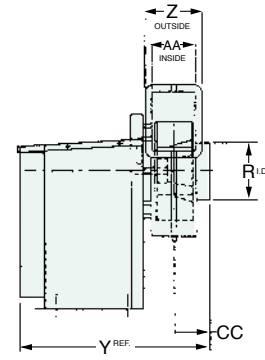
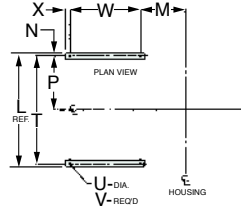
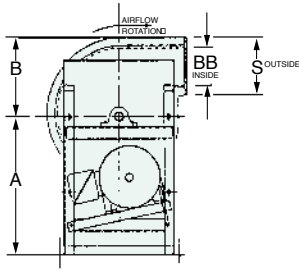

Principal Dimensions – Arrangement 10

Fan Size	A	B	C	D	E	F	G	H	J	L	M	N	P	R
10	18 ¹ / ₁₆	10 ⁵ / ₈	9	9 ⁵ / ₈	10 ¹ / ₈	13 ⁷ / ₈	9 ¹ / ₈	8 ⁵ / ₈	8 ¹ / ₈	21 ¹ / ₄	6 ¹⁵ / ₁₆	3/4	9 ⁷ / ₈	6
12	18 ¹ / ₁₆	11 ⁵ / ₈	10	10 ⁵ / ₈	11 ¹ / ₈	15 ⁵ / ₁₆	10 ¹ / ₈	9 ⁵ / ₈	9 ¹ / ₈	21 ¹ / ₄	7 ⁵ / ₁₆	3/4	9 ⁷ / ₈	7
14	18 ¹ / ₁₆	12 ⁵ / ₈	11	11 ⁵ / ₈	12 ¹ / ₈	16 ³ / ₄	11 ¹ / ₈	10 ⁵ / ₈	10 ¹ / ₈	21 ¹ / ₄	7 ⁹ / ₁₆	3/4	9 ⁷ / ₈	8

Fan Size	S	T	U	V	W	X	Y	Z	AA	BB	CC	Max. Motor Frame*	Max. Wgt. is Less Motor Wgt. & Accessories
10	7 ⁷ / ₁₆	19 ³ / ₄	9/16	4	12	2	30 ¹ / ₁₆	7	3 ³ / ₄	4 ³ / ₁₆	4 ¹ / ₄	182T	85
12	8 ¹ / ₄	19 ³ / ₄	9/16	4	12	2	30 ⁷ / ₁₆	7 ³ / ₄	4 ¹ / ₂	5	4 ⁵ / ₈	182T	90
14	9 ¹ / ₄	19 ³ / ₄	9/16	4	12	2	31 ⁵ / ₁₆	8 ¹ / ₄	5	6	4 ⁷ / ₈	182T	100

NOTE: Dimensions and specifications are subject to change. Certified prints are available.
 * For motor frame sizes larger than standard 182T, contact factory.

Series 42 - Arrangement 4

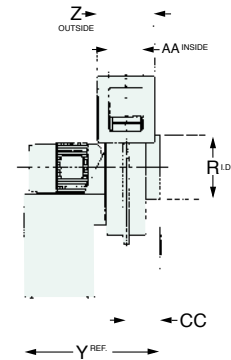
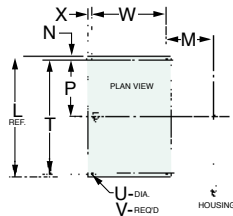
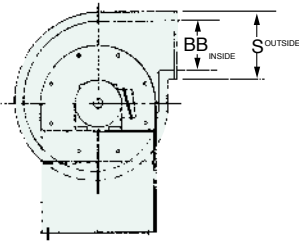

Principal Dimensions – Arrangement 4

Fan Size	A	B	C	D	E	F	G	H	J	K	L	M	N	P	R
10	12 ¹ / ₈	10 ⁵ / ₈	9	9 ⁵ / ₈	10 ¹ / ₈	13 ⁷ / ₈	9 ¹ / ₈	8 ⁵ / ₈	8 ¹ / ₈	17/8	13	5 ³ / ₈	1	5 ¹ / ₂	6
12	14 ¹ / ₈	11 ⁵ / ₈	10	10 ⁵ / ₈	11 ¹ / ₈	15 ⁵ / ₁₆	10 ¹ / ₈	9 ⁵ / ₈	9 ¹ / ₈	1 ³ / ₈	14 ¹ / ₂	5 ³ / ₄	1	6 ¹ / ₄	7
14	16 ¹ / ₈	12 ⁵ / ₈	11	11 ⁵ / ₈	12 ¹ / ₈	16 ³ / ₄	11 ¹ / ₈	10 ⁵ / ₈	10 ¹ / ₈	7/8	15 ¹ / ₂	5 ³ / ₈	1	6 ³ / ₄	8

Fan Size	S	T	U	V	W	X	Y	Z	AA	BB	CC	Min. Motor Frame	Max. Motor Frame	Max. Wgt. is Less Motor Wgt. & Accessories
10	7 ⁷ / ₁₆	11	7/16	4	4 ⁷ / ₈	1"	15 ¹¹ / ₁₆	7	3 ³ / ₄	4 ³ / ₁₆	4 ¹ / ₄	56	143T	63
12	8 ¹ / ₄	12 ¹ / ₂	7/16	4	5 ³ / ₈	1"	16 ¹⁵ / ₁₆	7 ³ / ₄	4 ¹ / ₂	5	4 ⁵ / ₈	56	184T	78
14	9 ¹ / ₄	13 ¹ / ₂	7/16	4	7 ³ / ₄	1"	19 ³ / ₁₆	8 ¹ / ₄	5	6	4 ⁷ / ₈	145T	213T	97

NOTE: Dimensions and specifications are subject to change. Certified prints are available.

Fan Discharges

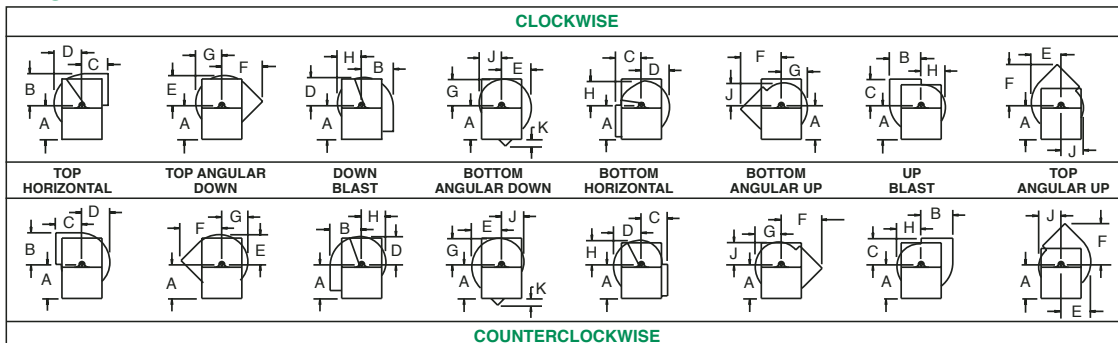

Performance Data

Size 10, A42- -10 - - F100FG

Outlet Area - 0.102 sq. ft. inside
Wheel Diameter - 10.5 in.
Wheel Circumference - 2.75 ft.

CFM	Outlet Velocity FPM	Static Pressure																	
		1"		2"		3"		4"		5"		6"		8"		10"		12"	
		RPM	BHP	RPM	BHP	RPM	BHP	RPM	BHP	RPM	BHP	RPM	BHP	RPM	BHP	RPM	BHP	RPM	BHP
100	980	1348	0.06	1863	0.14	2264	0.25												
150	1471	1424	0.08	1918	0.17	2309	0.28	2643	0.41	2939	0.56	3208	0.71						
200	1961	1522	0.11	1993	0.20	2371	0.33	2696	0.46	2987	0.62	3252	0.78	3726	1.14	4147	1.55	4528	1.99
250	2451	1645	0.15	2085	0.25	2449	0.38	2765	0.53	3049	0.69	3309	0.86	3775	1.24	4190	1.66	4568	2.12
300	2941	1793	0.20	2190	0.34	2541	0.45	2848	0.60	3123	0.78	3377	0.96	3835	1.35	4244	1.79	4617	2.26
350	3431	1955	0.27	2317	0.43	2644	0.58	2942	0.71	3210	0.87	3457	1.06	3905	1.49	4307	1.94	4675	2.42
400	3922	2126	0.35	2461	0.52	2762	0.72	3044	0.87	3306	1.02	3547	1.20	3985	1.63	4379	2.11	4741	2.61
450	4412	2300	0.45	2617	0.63	2898	0.85	3159	1.06	3409	1.23	3645	1.40	4074	1.79	4460	2.28	4815	2.82
500	4902	2477	0.56	2782	0.77	3045	0.99	3291	1.23	3524	1.47	3750	1.66	4170	2.02	4549	2.49	4898	3.03
550	5392	2658	0.71	2952	0.93	3202	1.16	3434	1.41	3655	1.68	3866	1.95	4271	2.36	4644	2.77		
600	5882	2843	0.87	3126	1.11	3366	1.36	3585	1.62	3795	1.91	3997	2.20	4381	2.73	4744	3.16		
650	6373	3032	1.06	3300	1.32	3535	1.59	3745	1.86	3944	2.15	4137	2.47	4502	3.10	4851	3.62		
700	6863	3224	1.28	3477	1.56	3708	1.84	3911	2.13	4101	2.43	4284	2.75	4634	3.44				
750	7353	3418	1.54	3657	1.83	3881	2.13	4080	2.44	4264	2.75	4439	3.08	4775	3.79				
800	7843	3615	1.82	3841	2.13	4055	2.45	4252	2.78	4431	3.11	4600	3.45	4922	4.17				

Size 12, A42- -12 - - F100FG

Outlet Area - 0.148 sq. ft. inside
Wheel Diameter - 12.5 in.
Wheel Circumference - 3.27 ft.

CFM	Outlet Velocity FPM	Static Pressure																	
		1"		2"		3"		4"		5"		6"		8"		10"		12"	
		RPM	BHP	RPM	BHP	RPM	BHP	RPM	BHP	RPM	BHP	RPM	BHP	RPM	BHP	RPM	BHP	RPM	BHP
180	1216	1137	0.08	1563	0.18	1893	0.29	2174	0.43										
240	1622	1179	0.10	1599	0.21	1926	0.34	2202	0.48	2447	0.64	2670	0.81	3069	1.20				
300	2027	1239	0.13	1637	0.25	1962	0.39	2238	0.55	2480	0.71	2700	0.89	3093	1.29	3443	1.73	3761	2.21
360	2432	1310	0.16	1686	0.30	1999	0.45	2274	0.62	2518	0.80	2736	0.99	3126	1.40	3471	1.86	3785	2.35
420	2838	1390	0.21	1747	0.35	2046	0.52	2312	0.70	2553	0.89	2773	1.10	3162	1.53	3505	2.01	3816	2.52
480	3243	1478	0.26	1816	0.42	2103	0.60	2358	0.79	2592	0.99	2809	1.21	3199	1.67	3542	2.17	3852	2.70
540	3649	1572	0.33	1893	0.50	2168	0.69	2414	0.89	2640	1.11	2849	1.33	3234	1.82	3578	2.35	3889	2.91
600	4054	1671	0.41	1975	0.60	2239	0.80	2477	1.01	2696	1.24	2899	1.47	3273	1.98	3614	2.53	3925	3.12
660	4459	1774	0.50	2062	0.70	2316	0.92	2546	1.15	2758	1.38	2956	1.63	3319	2.16	3652	2.73	3960	3.34
720	4865	1878	0.61	2154	0.83	2398	1.06	2620	1.30	2825	1.55	3018	1.81	3372	2.36	3696	2.95	3999	3.58
780	5270	1984	0.73	2250	0.97	2484	1.21	2698	1.47	2898	1.73	3085	2.00	3431	2.58	3747	3.19	4042	3.84
840	5676	2090	0.87	2349	1.13	2573	1.39	2781	1.66	2974	1.93	3156	2.22	3494	2.82	3804	3.46	4092	4.13
900	6081	2197	1.02	2451	1.30	2666	1.58	2867	1.86	3055	2.16	3232	2.46	3561	3.08	3864	3.74	4147	4.43
960	6486	2305	1.20	2555	1.50	2763	1.79	2956	2.09	3139	2.40	3311	2.72	3632	3.37	3929	4.05		
1020	6892	2414	1.39	2660	1.72	2863	2.03	3049	2.34	3226	2.67	3394	3.00	3707	3.68	3997	4.39		

Size 14, A42- -14 - - F100FG

Outlet Area - 0.198 sq. ft. inside
Wheel Diameter - 14.5 in.
Wheel Circumference - 3.80 ft.

CFM	Outlet Velocity FPM	Static Pressure																	
		1"		2"		3"		4"		5"		6"		8"		10"		12"	
		RPM	BHP	RPM	BHP	RPM	BHP	RPM	BHP	RPM	BHP	RPM	BHP	RPM	BHP	RPM	BHP	RPM	BHP
240	1212	982	0.08	1348	0.17	1638	0.29	1887	0.42										
320	1616	1037	0.11	1379	0.21	1660	0.34	1901	0.47	2117	0.63	2313	0.79	2670	1.16				
400	2020	1110	0.15	1426	0.27	1693	0.40	1928	0.55	2139	0.71	2331	0.88	2676	1.26	2985	1.69	3269	2.15
480	2424	1193	0.20	1489	0.34	1740	0.48	1964	0.64	2169	0.81	2358	0.99	2697	1.39	2999	1.82	3276	2.30
560	2828	1281	0.26	1564	0.42	1800	0.58	2013	0.75	2209	0.93	2392	1.12	2724	1.54	3023	1.99	3294	2.48
640	3232	1372	0.34	1647	0.51	1871	0.69	2073	0.88	2261	1.08	2436	1.28	2759	1.71	3051	2.18	3320	2.69
720	3636	1466	0.43	1732	0.62	1950	0.82	2143	1.03	2322	1.25	2490	1.46	2801	1.92	3086	2.41	3350	2.93
800	4040	1563	0.53	1821	0.75	2034	0.97	2220	1.20	2391	1.43	2553	1.67	2853	2.15	3129	2.66	3387	3.21
880	4444	1664	0.66	1912	0.90	2120	1.14	2302	1.38	2468	1.63	2623	1.89	2912	2.41	3180	2.95	3430	3.51
960	4848	1769	0.81	2004	1.07	2208	1.33	2387	1.59	2549	1.86	2699	2.14	2978	2.70	3238	3.27	3481	3.86
1040	5253	1877	0.98	2099	1.26	2299	1.55	2474	1.83	2633	2.11	2780	2.40	3051	3.01	3301	3.62	3538	4.24
1120	5657	1986	1.19	2196	1.47	2390	1.78	2563	2.09	2719	2.39	2864	2.70	3128	3.34	3371	3.99		
1200	6061	2097	1.42	2296	1.71	2483	2.04	2653	2.38	2807	2.70	2949	3.03	3210	3.70	3447	4.39		
1280	6465	2209	1.68	2400	1.99	2578	2.33	2745	2.69	2896	3.04	3037	3.39	3293	4.09	3526	4.81		
1360	6869	2322	1.97	2505	2.30	2675	2.65	2837	3.03	2988	3.41	3125	3.78	3378	4.52				

Performance shown is for belt drive fans, installation Type D: ducted inlet/ducted outlet. Power ratings (BHP) do not include drive losses. Performance ratings do not include the effects of appurtenances in the airstream. **MOST EFFICIENT FAN SELECTION APPEARS IN SHADED PRINT.** To complete the model code, add arrangement, motor enclosure code, motor horsepower code and motor speed code. See page 2 for the complete Hartzell Model Code Explanation and example.

A42-4- -F100FG (Direct Drive)

Size	Model	Motor HP	Motor (Fan) RPM	Peak Fan BHP	Cubic Feet Per Minute AT Static Pressure																				
					0"	1/2"	1"	1 1/2"	2"	2 1/2"	3"	4"	5"	6"	7"	8"	9"	10"	11"	12"	13"				
					10	A42-4-10-F100FG_F3 A42-4-10-F100FG_L2	1/2 1 1/2	1725 3450	1.60	408	346	278	173	788	758	726	692	658	625	556	469	346			
12	A42-4-12-F100FG_F3 A42-4-12-F100FG_K2 A42-4-12-F100FG_L2	1/2 3 5	1725 3500 3500	3.38 3.38	837	731	632	530	399	158							1094	979	846	675	411				
14	A42-4-14-F100FG_H3 A42-4-14-F100FG_L2 A42-4-14-F100FG_M2	1 5 7 1/2	1725 3500 3500	5.45 5.45	1109	1020	927	822	713	602	457							1579	1472	1364	1255	1135	988	780	780

Performance shown is for installation Type D: ducted inlet/ducted outlet. Performance ratings are based on standard air conditions (0.075 lbs/cu. ft). Performance ratings do not include the effects of appurtenances in the airstream. **CFM exceeds 8,000 FPM outlet velocity, please contact factory.** **MOST EFFICIENT FAN SELECTION APPEARS IN SHADED PRINT.** Bold type information provided in the Rating Table above is needed when preparing a model code. See page 2 for the complete Hartzell Model Code Explanation and example.



Fiberglass Radial Blower (Belt Drive)

Series 43

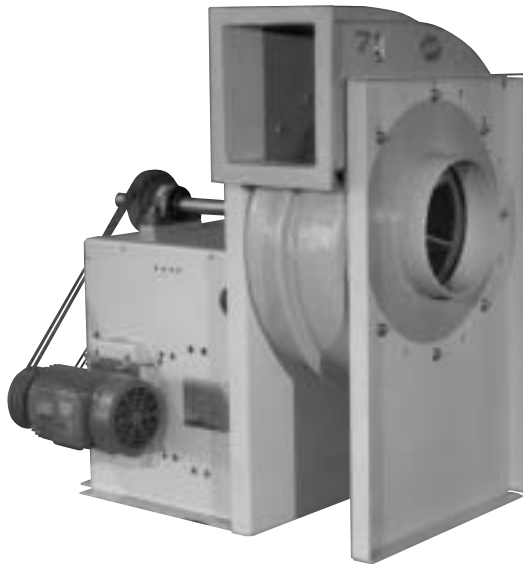

Hartzell Fan, Inc. certifies that the Series 43, Fiberglass Radial Blower, shown hereon is licensed to bear the AMCA Seal. The ratings shown are based on tests and procedures performed in accordance with AMCA Publication 211 and comply with the requirements of the AMCA Certified Ratings Program.



**Type F Wheel
(Series 43)**

Blowers available in SWSI only

This versatile corrosive resistant air moving blower is suited for installation where air flows at static pressures up to 16". The housing is constructed with a special corrosive resistant polyester resin having a Class I flame spread rate of 25 or less. The wheel is made using a special corrosion resistant vinylester resin having a Class I flame spread rate of 30 or less. No metal parts are exposed in the airstream. All internal hardware is 300 series stainless steel encapsulated.

Features

- **Sizes** – 16", 19", 23", 26", 30", and 33" wheel diameters.
- **Arrangements** – available in Arrangements #1, #9 or #10.
- **Temperature Limitations** – suitable for temperatures up to 250°F. See Table 3, page 12 for maximum safe speed correction factors at high temperatures.
- **FRP Materials** – solid fiberglass wheel molded with Dow Derakane 510-A vinylester resin. Other standard FRP components constructed of fiberglass and Ashland Hetron 693 resin. See Corrosion Resistance Guide on page 13 for resin characteristics. Other resins are available.
- **Rotation** – **clockwise rotation standard.** Counterclockwise rotation available.
- **Discharges** – available discharges shown on page 8. **Rotatable in field.**
- **Easy installation and maintenance** – motor, drive and bearings are readily accessible for ease in wiring, installation, adjustment and lubrication.
- **Wheel** – a multi-piece radial design is of solid fiberglass construction bonded together with resin and fiberglass material. **Wheel Type F.**
- **Motors** – are available to your specifications, mounted and test run at the factory prior to shipment.
- **Drive Assembly (Belt Drive Fans)** – belts are oil, heat and static resistant type, oversized for continuous duty. Shafts are turned, ground and polished, keyed at both ends.
- **Bearings** – heavy-duty, self-aligning, pillow block bearings are standard.
- **Shafts** – turned, ground and polished. Fiberglass enclosed in the airstream. Stainless steel (304 or 316) or monel shafting is available as an option at extra cost.
- **Shaft Seal** – a fiberglass and neoprene shaft seal is placed where the shaft leaves the housing along with a neoprene shaft slinger between the seal and wheel on belt drive units. Seal is not gas tight.
- **Flanged outlets are standard.** Inlet flanges are optional. Drilling of flanges is optional.
- **Bases** – heavy gauge hot rolled steel, epoxy coated.
- **All units are test run and electronically balanced** before shipment.
- **Accessories** – See pages 14 and 15.



Series 43 - Arrangement 1, 9 or 10

Sizes 16 through 26

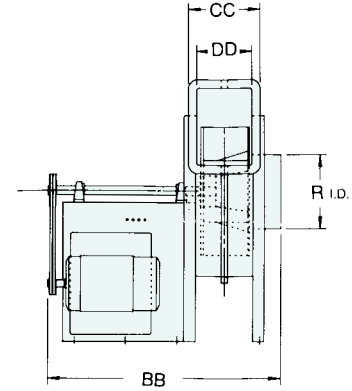
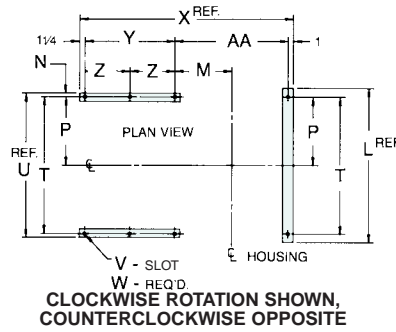
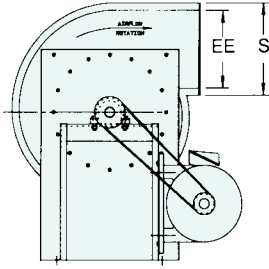

Principal Dimensions

Fan Size	A	B	C	D	E	F	G	H	J	L	M	N	P	R	S	T
16	21 ¹ / ₂	14 ⁷ / ₈	12 ¹ / ₈	13 ¹¹ / ₁₆	14 ¹ / ₄	19 ¹ / ₁₆	13 ¹ / ₁₆	12 ¹ / ₂	11 ⁷ / ₈	20 ³ / ₄	6 ¹ / ₄	1	9 ¹ / ₈	9	12 ¹ / ₁₆	18 ¹ / ₄
19	24 ¹ / ₄	18	15	16 ¹ / ₂	17 ¹ / ₄	23 ³ / ₈	15 ³ / ₄	15	14 ¹ / ₄	27 ³ / ₄	8 ¹¹ / ₁₆	1 ⁵ / ₁₆	12 ¹¹ / ₁₆	11	14	25 ³ / ₈
23	30	20 ⁷ / ₈	18 ¹ / ₄	19 ¹ / ₈	20	27 ¹¹ / ₁₆	18 ¹ / ₄	17 ³ / ₈	16 ¹ / ₂	28 ¹ / ₈	7 ¹⁵ / ₁₆	1	12 ¹¹ / ₁₆	13	16	25 ³ / ₈
26	30	23 ¹³ / ₁₆	20 ¹ / ₄	21 ¹³ / ₁₆	22 ¹³ / ₁₆	31 ¹ / ₈	20 ¹³ / ₁₆	19 ¹³ / ₁₆	18 ¹³ / ₁₆	28 ¹ / ₈	8 ¹³ / ₁₆	1	12 ¹¹ / ₁₆	15	18	25 ³ / ₈

Fan Size	U	V	W	X	Y	Z	AA	BB	CC	DD	EE	Max. Motor Frame	Max. Wgt. is Less Motor Wgt. & Accessories
16	20 ¹ / ₄	1 ¹¹ / ₁₆ x 1 ¹ / ₁₆	6	29 ¹ / ₂	15 ³ / ₄	-	11 ¹ / ₂	34 ¹ / ₈	10 ¹ / ₂	7 ¹ / ₄	8 ¹³ / ₁₆	215T	315
19	27 ¹ / ₄	1 ¹¹ / ₁₆ x 1 ¹ / ₁₆	8	35 ⁷ / ₈	18 ³ / ₄	9 ³ / ₈	14 ⁷ / ₈	41 ¹ / ₂	12 ¹ / ₈	8 ⁷ / ₈	10 ³ / ₄	256T	394
23	27 ³ / ₈	1 ¹¹ / ₁₆ x 1 ¹ / ₁₆	8	37 ⁵ / ₈	20 ¹ / ₄	10 ¹ / ₈	15 ¹ / ₈	45	13 ³ / ₄	10 ¹ / ₂	12 ³ / ₄	286T	485
26	27 ³ / ₈	1 ¹¹ / ₁₆ x 1 ¹ / ₁₆	8	39 ⁷ / ₁₆	20 ¹ / ₄	10 ¹ / ₈	16 ¹⁵ / ₁₆	47 ¹³ / ₁₆	15 ³ / ₈	12 ¹ / ₈	14 ³ / ₄	286T	560

Dimensions and specifications are subject to change. Certified prints are available.

Sizes 30 and 33

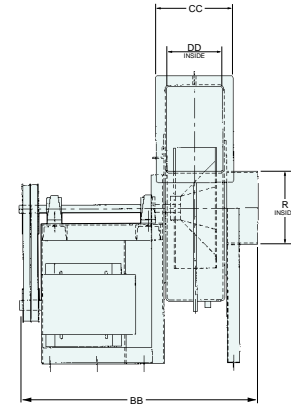
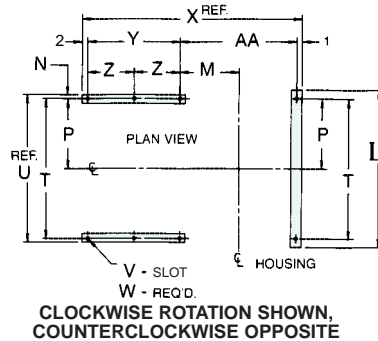
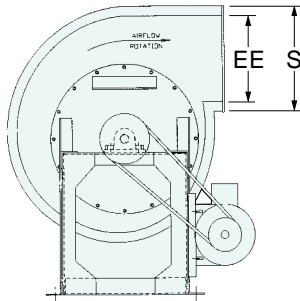

Principal Dimensions

Fan Size	A	B	C	D	E	F	G	H	J	L	M	N	P	R	S	T
30	37	26 ⁷ / ₈	22 ³ / ₄	24 ⁹ / ₁₆	25 ³ / ₄	35 ¹ / ₁₆	23 ⁷ / ₁₆	22 ⁵ / ₁₆	21 ³ / ₁₆	35 ³ / ₄	12 ⁹ / ₁₆	2 ¹ / ₈	16 ⁷ / ₈	17	20	33 ³ / ₄
33	37	29 ⁹ / ₁₆	25 ¹ / ₂	27 ¹ / ₁₆	28 ⁵ / ₁₆	39	25 ⁷ / ₈	24 ⁹ / ₁₆	23 ⁵ / ₁₆	35 ³ / ₄	13 ³ / ₈	2 ¹ / ₈	16 ⁷ / ₈	19	21 ⁷ / ₈	33 ³ / ₄

Fan Size	U	V	W	X	Y	Z	AA	BB	CC	DD	EE	Max. Motor Frame	Max. Wgt. is Less Motor Wgt. & Accessories
30	38	1 ¹³ / ₁₆ x 1 ¹ / ₄	8	47 ⁵ / ₁₆	22 ³ / ₄	11 ³ / ₈	21 ⁹ / ₁₆	56	17	13 ³ / ₄	16 ³ / ₄	286T	646
33	38	1 ¹³ / ₁₆ x 1 ¹ / ₄	8	49 ¹⁵ / ₁₆	22 ³ / ₄	11 ³ / ₈	23 ³ / ₁₆	58 ¹ / ₈	18 ⁹ / ₁₆	15 ⁵ / ₁₆	18 ⁵ / ₈	286T	710

Dimensions and specifications are subject to change. Certified prints are available.

Fan Discharges

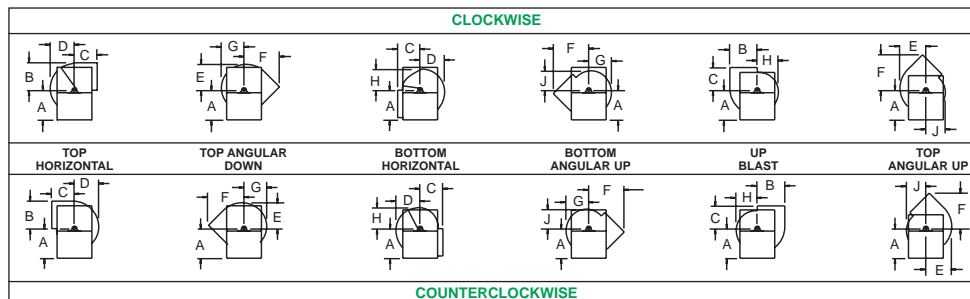

Note:
For angular and/or down blast, contact factory when discharge flanges are required.



Performance Data

Size 16, A43- -16 - - F100FG

SWSI
 Outlet Area – 0.444 sq. ft. inside
 Wheel Diameter – 15.625 in.
 Wheel Circumference – 4.091 ft.
 Inlet Diameter – 9 in. I.D.

CFM	Outlet Velocity FPM	Static Pressure																								
		1"		2"		3"		4"		5"		6"		7"		8"		10"		12"		14"		16"		
		RPM	BHP	RPM	BHP	RPM	BHP	RPM	BHP	RPM	BHP	RPM	BHP	RPM	BHP	RPM	BHP	RPM	BHP	RPM	BHP	RPM	BHP	RPM	BHP	
500	1126	938	0.16	1251	0.33	1498	0.51	1710	0.71	1898	0.93	2068	1.16													
600	1351	979	0.20	1285	0.39	1528	0.59	1737	0.81	1922	1.04	2091	1.29	2247	1.55	2393	1.82									
700	1577	1025	0.24	1324	0.46	1561	0.68	1766	0.92	1950	1.17	2117	1.43	2272	1.71	2417	2.00	2682	2.60	2924	3.25					
800	1802	1079	0.31	1364	0.53	1598	0.78	1800	1.04	1980	1.31	2146	1.59	2299	1.89	2442	2.19	2706	2.83	2946	3.51	3167	4.23			
900	2027	1135	0.38	1407	0.60	1638	0.89	1836	1.17	2014	1.46	2177	1.77	2329	2.08	2471	2.40	2732	3.08	2970	3.79	3191	4.54	3396	5.32	
1000	2252	1193	0.46	1455	0.70	1679	0.99	1876	1.31	2051	1.63	2211	1.95	2361	2.29	2501	2.63	2760	3.34	2997	4.09	3216	4.87	3420	5.69	
1100	2477	1253	0.56	1508	0.82	1722	1.10	1917	1.45	2090	1.80	2248	2.15	2395	2.50	2534	2.87	2791	3.62	3025	4.40	3242	5.22	3446	6.07	
1200	2703	1316	0.67	1564	0.96	1769	1.24	1958	1.59	2131	1.98	2287	2.35	2433	2.73	2570	3.12	2823	3.92	3056	4.74	3271	5.59	3473	6.48	
1300	2928	1384	0.81	1621	1.11	1822	1.42	2002	1.75	2171	2.15	2328	2.57	2472	2.98	2608	3.39	2858	4.23	3088	5.10	3302	5.99	3502	6.90	
1400	3153	1455	0.95	1679	1.28	1877	1.62	2050	1.94	2214	2.33	2369	2.77	2513	3.23	2647	3.66	2895	4.56	3122	5.47	3334	6.40	3533	7.36	
1500	3378	1528	1.12	1738	1.47	1933	1.83	2103	2.18	2260	2.55	2411	2.99	2554	3.46	2688	3.95	2934	4.89	3158	5.85	3368	6.84	3565	7.84	
1600	3604	1600	1.31	1799	1.68	1989	2.06	2158	2.45	2310	2.82	2455	3.23	2595	3.71	2728	4.22	2974	5.24	3197	6.26	3404	7.28	3599	8.33	
1700	3829	1674	1.52	1863	1.91	2048	2.31	2214	2.73	2364	3.12	2503	3.52	2639	3.99	2770	4.51	3015	5.60	3236	6.67	3442	7.75	3635	8.85	
1800	4054	1748	1.75	1931	2.17	2107	2.59	2270	3.03	2419	3.46	2556	3.87	2686	4.30	2813	4.82	3055	5.94	3277	7.10	3481	8.23	3673	9.37	
1900	4279	1823	2.01	2001	2.45	2167	2.89	2328	3.35	2475	3.81	2610	4.25	2737	4.69	2859	5.17	3097	6.29	3318	7.52	3521	8.72			
2000	4505	1898	2.29	2073	2.76	2229	3.22	2386	3.69	2531	4.18	2665	4.66	2790	5.12	2910	5.59	3140	6.68	3358	7.92	3563	9.23			
2100	4730	1975	2.60	2145	3.10	2294	3.58	2445	4.07	2588	4.58	2721	5.09	2845	5.58	2962	6.06	3186	7.11	3400	8.36	3603	9.70			
2200	4955	2052	2.94	2217	3.46	2362	3.97	2506	4.48	2647	5.00	2778	5.54	2907	6.07	3017	6.58	3234	7.61	3444	8.83	3644	10.20			
2300	5180	2130	3.32	2290	3.86	2432	4.39	2568	4.92	2705	5.46	2835	6.01	2957	6.58	3072	7.13	3287	8.18	3489	9.34	3686	10.70			
2400	5405	2208	3.72	2364	4.28	2503	4.84	2632	5.39	2765	5.95	2893	6.52	3014	7.11	3128	7.69	3340	8.80	3538	9.93					
2500	5631	2286	4.15	2438	4.73	2575	5.33	2699	5.90	2826	6.48	2952	7.07	3071	7.67	3184	8.28	3395	9.47	3590	10.60					
2600	5856	2365	4.62	2512	5.22	2647	5.85	2769	6.44	2889	7.04	3012	7.65	3130	8.27	3241	8.90	3451	10.20	3643	11.40					
2700	6081	2444	5.13	2587	5.75	2720	6.40	2839	7.02	2954	7.64	3072	8.27	3189	8.90	3299	9.55	3507	10.90							
2800	6306	2524	5.67	2663	6.31	2793	6.98	2911	7.64	3021	8.28	3135	8.92	3248	9.58	3358	10.20									
2900	6532	2603	6.25	2739	6.92	2866	7.61	2983	8.29	3091	8.95	3198	9.62	3308	10.30	3417	11.00									
3000	6757	2683	6.87	2816	7.56	2940	8.27	3055	8.98	3161	9.67	3264	10.40	3370	11.10											
3100	6982	2763	7.53	2893	8.25	3014	8.97	3128	9.71	3232	10.40	3332	11.10													
3200	7207	2844	8.24	2971	8.97	3089	9.72	3200	10.50	3304	11.20															
3300	7432	2924	8.98	3049	9.75	3164	10.50	3274	11.30																	
3400	7658	3005	9.77	3127	10.60	3239	11.30																			
3500	7883	3086	10.60	3205	11.40																					
3600	8108	3167	11.50																							

Size 19, A43- -19 - - F100FG

SWSI
 Outlet Area – 0.663 sq. ft. inside
 Wheel Diameter – 19.125 in.
 Wheel Circumference – 5.007 ft.
 Inlet Diameter – 11 in. I.D.

CFM	Outlet Velocity FPM	Static Pressure																								
		1"		2"		3"		4"		5"		6"		7"		8"		10"		12"		14"		16"		
		RPM	BHP	RPM	BHP	RPM	BHP	RPM	BHP	RPM	BHP	RPM	BHP	RPM	BHP	RPM	BHP	RPM	BHP	RPM	BHP	RPM	BHP	RPM	BHP	
700	1056	756	0.23	1013	0.46	1217	0.73	1391	1.02	1544	1.33															
850	1282	789	0.28	1040	0.55	1240	0.85	1411	1.16	1564	1.50	1702	1.86	1830	2.24											
1000	1508	824	0.34	1071	0.65	1266	0.98	1435	1.32	1585	1.69	1723	2.07	1849	2.48	1968	2.90	2185	3.79							
1150	1735	867	0.43	1104	0.76	1296	1.12	1461	1.50	1610	1.89	1745	2.31	1871	2.74	1988	3.19	2204	4.13	2401	5.13	2582	6.19			
1300	1961	912	0.53	1138	0.86	1328	1.28	1490	1.69	1636	2.12	1770	2.56	1894	3.02	2011	3.49	2225	4.49	2420	5.54	2600	6.65	2769	7.80	
1450	2187	959	0.65	1175	0.99	1361	1.43	1522	1.89	1666	2.36	1797	2.83	1920	3.32	2035	3.82	2248	4.87	2441	5.97	2620	7.13	2788	8.34	
1600	2413	1008	0.79	1218	1.17	1395	1.60	1555	2.11	1697	2.61	1827	3.12	1948	3.65	2062	4.18	2272	5.28	2464	6.44	2642	7.65	2808	8.91	
1750	2640	1058	0.95	1263	1.37	1432	1.79	1589	2.31	1730	2.88	1858	3.43	1978	3.99	2090	4.55	2298	5.72	2488	6.93	2665	8.19	2830	9.50	
1900	2866	1113	1.14	1309	1.59	1474	2.04	1624	2.54	1763	3.13	1892	3.74	2009	4.34	2120	4.95	2326	6.18	2514	7.46	2689	8.78	2854	10.10	
2050	3092	1170	1.36	1356	1.84	1519	2.33	1662	2.81	1798	3.40	1925	4.06	2043	4.71	2152	5.36	2355	6.67	2542	8.01	2715	9.39	2878	10.80	
2200	3318	1229	1.60	1405	2.11	1564	2.64	1704	3.15	1834	3.71	1958	4.37	2076	5.08	2186	5.78	2387	7.17	2571	8.59	2743	10.00	2904	11.50	
2350	3544	1289	1.87	1454	2.41	1611	2.98	1749	3.54	1874	4.08	1994	4.72	2109	5.44	2219	6.20	2419	7.69	2602	9.18	2772	10.70	2932	12.30	
2500	3771	1348	2.17	1506	2.75	1658	3.35	1794	3.96	1917	4.53	2032	5.13	2145	5.84	2252	6.61	2453	8.23	2634	9.80	2802	11.40	2961	13.00	
2650	3997	1409	2.51	1560	3.13	1706	3.75	1840	4.39	1962	5.02	2074	5.63	2182	6.29	2287	7.07	2486	8.74	2667	10.40	2834	12.10	2991	13.80	
2800	4223	1470	2.88	1617	3.54	1755	4.19	1887	4.86	2008	5.54	2118	6.19	2223	6.84	2324	7.57	2519	9.26	2700	11.10	2867	12.80	3022	14.60	
2950	4449	1532	3.30	1675	3.99	1805	4.67	1935	5.37	2053	6.09	2163	6.79	2266	7.47	2364	8.16	2554	9.82	2733	11.70	2900	13.60			
3100	4676	1594	3.75	1734	4.49	1858	5.20	1983	5.92	2100	6.67	2209	7.43	2311	8.15	2407	8.86	2591	10.40	2767	12.30	2933	14.30			
3250	4902	1657	4.25	1793	5.02	1912	5.76	2032	6.52	2147	7.29	2255	8.09	2356	8.87	2451	9.61	2630	11.10	2802	13.00	2966	15.00			
3400	5128	1720	4.79	1853	5.59	1969	6.38	2082	7.16	2196	7.96	2302	8.79	2402	9.62											

Size 23, A43- -23 - - F100FG

SWSI
 Outlet Area - 0.930 sq. ft. inside
 Wheel Diameter - 22.625 in.
 Wheel Circumference - 5.923 ft.
 Inlet Diameter - 13 in. I.D.

CFM	Outlet Velocity FPM	Static Pressure																							
		1"		2"		3"		4"		5"		6"		7"		8"		10"		12"		14"		16"	
		RPM	BHP	RPM	BHP	RPM	BHP	RPM	BHP	RPM	BHP	RPM	BHP	RPM	BHP	RPM	BHP	RPM	BHP	RPM	BHP	RPM	BHP	RPM	BHP
1000	1075	641	0.33	859	0.66	1031	1.03	1177	1.45	1307	1.89	1440	2.62	1548	3.15	1649	3.71								
1200	1290	668	0.40	880	0.78	1049	1.19	1194	1.64	1323	2.12	1440	2.62	1548	3.15	1649	3.71								
1400	1505	697	0.47	905	0.91	1070	1.37	1213	1.85	1340	2.36	1456	2.90	1563	3.47	1664	4.06								
1600	1720	731	0.59	932	1.05	1094	1.56	1234	2.09	1360	2.64	1474	3.21	1581	3.81	1680	4.44	1863	5.76	2029	7.16	2182	8.63		
1800	1935	768	0.73	959	1.19	1120	1.77	1257	2.34	1381	2.94	1494	3.55	1599	4.18	1698	4.84	1879	6.23	2044	7.70	2197	9.24	2339	10.90
2000	2151	805	0.88	989	1.36	1147	1.98	1283	2.61	1404	3.25	1516	3.91	1620	4.59	1717	5.28	1897	6.74	2061	8.27	2213	9.88	2354	11.60
2200	2366	844	1.07	1023	1.59	1174	2.19	1309	2.89	1429	3.59	1539	4.29	1642	5.01	1738	5.75	1917	7.28	2079	8.89	2230	10.60	2426	12.30
2400	2581	884	1.28	1059	1.85	1203	2.43	1336	3.17	1456	3.94	1565	4.69	1666	5.46	1761	6.25	1937	7.86	2098	9.53	2248	11.30	2388	13.10
2600	2796	927	1.52	1096	2.14	1236	2.75	1364	3.46	1483	4.29	1591	5.11	1691	5.93	1785	6.77	1959	8.47	2119	10.20	2267	12.00	2406	13.90
2800	3011	973	1.79	1133	2.45	1271	3.12	1394	3.80	1510	4.63	1618	5.54	1717	6.42	1810	7.31	1983	9.11	2141	11.00	2288	12.90	2426	14.80
3000	3226	1020	2.11	1172	2.80	1308	3.53	1427	4.22	1538	5.02	1645	5.95	1744	6.92	1837	7.87	2007	9.77	2164	11.70	2310	13.70	2447	15.70
3200	3441	1068	2.45	1211	3.19	1345	3.97	1462	4.72	1569	5.47	1673	6.39	1771	7.40	1864	8.44	2033	10.50	2188	12.50	2332	14.60	2468	16.70
3400	3656	1116	2.84	1252	3.62	1383	4.43	1499	5.26	1603	6.04	1702	6.90	1799	7.91	1890	8.98	2060	11.20	2213	13.30	2356	15.50	2491	17.70
3600	3871	1164	3.26	1294	4.10	1421	4.95	1535	5.82	1639	6.66	1735	7.50	1828	8.47	1918	9.55	2087	11.90	2240	14.10	2381	16.40	2515	18.70
3800	4086	1213	3.74	1339	4.62	1460	5.51	1573	6.43	1675	7.34	1769	8.21	1859	9.11	1947	10.20	2113	12.50	2267	15.00	2407	17.40	2540	19.80
4000	4301	1263	4.25	1386	5.20	1500	6.12	1611	7.07	1712	8.05	1805	8.98	1893	9.90	1977	10.90	2141	13.30	2293	15.80	2434	18.40		
4200	4516	1313	4.82	1433	5.82	1541	6.78	1649	7.77	1749	8.79	1842	9.81	1928	10.80	2010	11.70	2169	14.00	2320	16.60	2461	19.40		
4400	4731	1363	5.45	1481	6.49	1583	7.50	1688	8.53	1787	9.58	1879	10.70	1964	11.70	2045	12.70	2200	14.90	2348	17.50	2488	20.30		
4600	4946	1414	6.13	1528	7.22	1628	8.27	1728	9.34	1825	10.40	1916	11.60	2001	12.70	2081	13.70	2232	15.90	2376	18.40	2515	21.30		
4800	5161	1465	6.86	1576	8.00	1674	9.11	1769	10.20	1864	11.30	1954	12.50	2038	13.70	2118	14.80	2266	17.00	2406	19.50	2542	22.30		
5000	5376	1516	7.66	1625	8.83	1721	10.00	1811	11.10	1903	12.30	1992	13.50	2075	14.70	2154	16.00	2301	18.30	2438	20.60				
5200	5591	1568	8.52	1673	9.73	1768	11.00	1855	12.10	1943	13.40	2031	14.60	2113	15.80	2191	17.10	2337	19.60	2472	22.00				
5400	5806	1620	9.45	1722	10.70	1816	12.00	1900	13.20	1985	14.50	2070	15.70	2151	17.00	2229	18.30	2374	20.90	2507	23.40				
5600	6022	1672	10.40	1772	11.70	1864	13.10	1947	14.40	2027	15.60	2109	16.90	2190	18.30	2267	19.60	2411	22.40	2543	25.00				
5800	6237	1724	11.50	1821	12.80	1912	14.20	1993	15.60	2071	16.90	2150	18.20	2229	19.60	2305	21.00	2447	23.80						
6000	6452	1777	12.60	1871	14.00	1960	15.40	2041	16.80	2116	18.20	2192	19.60	2269	21.00	2344	22.40	2485	25.30						
6200	6667	1829	13.80	1922	15.30	2008	16.70	2088	18.20	2162	19.60	2234	21.00	2309	22.50	2383	23.90	2523	26.90						
6400	6882	1882	15.10	1973	16.60	2057	18.10	2136	19.60	2209	21.10	2279	22.60	2350	24.00	2422	25.50								
6600	7097	1935	16.50	2024	18.00	2106	19.50	2184	21.10	2256	22.70	2324	24.20	2393	25.70	2463	27.20								
6800	7312	1988	17.90	2075	19.50	2155	21.10	2232	22.70	2303	24.30	2370	25.90	2436	27.40	2504	29.00								
7000	7527	2041	19.50	2126	21.10	2205	22.70	2280	24.40	2351	26.00	2417	27.60	2481	29.20	2546	30.90								
7200	7742	2094	21.10	2178	22.80	2255	24.40	2329	26.10	2399	27.80	2464	29.50	2527	31.20										

Size 26, A43- -26 - - F100FG

SWSI
 Outlet Area - 1.242 sq. ft. inside
 Wheel Diameter - 26.125 in.
 Wheel Circumference - 6.84 ft.
 Inlet Diameter - 15 in. I.D.

CFM	Outlet Velocity FPM	Static Pressure																							
		1"		2"		3"		4"		5"		6"		7"		8"		10"		12"		14"		16"	
		RPM	BHP	RPM	BHP	RPM	BHP	RPM	BHP	RPM	BHP	RPM	BHP	RPM	BHP	RPM	BHP	RPM	BHP	RPM	BHP	RPM	BHP	RPM	BHP
1250	1006	549	0.41	738	0.83	888	1.32	1015	1.85																
1500	1208	570	0.49	755	0.98	902	1.51	1028	2.08	1140	2.70	1242	3.36	1336	4.06										
1750	1409	592	0.58	774	1.14	919	1.72	1043	2.34	1154	3.00	1255	3.70	1348	4.44	1435	5.21								
2000	1610	618	0.70	795	1.31	937	1.95	1059	2.62	1169	3.33	1269	4.07	1361	4.85	1448	5.66	1606	7.37	1751	9.19				
2250	1812	647	0.86	817	1.48	957	2.20	1077	2.93	1185	3.69	1284	4.47	1376	5.30	1462	6.15	1619	7.95	1763	9.85	1895	11.90	2019	14.00
2500	2013	677	1.05	840	1.67	979	2.46	1097	3.25	1203	4.07	1301	4.91	1392	5.78	1477	6.67	1633	8.56	1776	10.50	1907	12.60	2030	14.80
2750	2214	708	1.25	865	1.90	1000	2.72	1118	3.60	1223	4.47	1319	5.37	1409	6.29	1493	7.24	1648	9.20	1790	11.30	1921	13.50	2043	15.70
3000	2415	740	1.49	893	2.20	1023	2.99	1140	3.96	1244	4.90	1339	5.86	1427	6.83	1510	7.83	1664	9.90	1805	12.10	1935	14.30	2057	16.70
3250	2617	773	1.76	923	2.54	1047	3.31	1162	4.29	1265	5.34	1359	6.36	1447	7.40	1529	8.46	1681	10.60	1821	12.90	1950	15.20	2071	17.70
3500	2818	808	2.07	953	2.90	1074	3.72	1184	4.67	1287	5.77	1371	6.89	1467	7.99	1549	9.11	1699	11.40	1837	13.80	1966	16.20	2086	18.70
3750	3019	845	2.42	984	3.30	1103	4.19	1209	5.10	1309	6.21	1403	7.42	1489	8.61	1569	9.79	1718	12.20	1855	14.70	1983	17.20	2102	19.80
4000	3221	884	2.81	1015	3.74	1133	4.71	1236	5.63	1332	6.70	1424	7.93	1511	9.23	1591	10.50	1738	13.00	1874	15.60	2000	18.30	2119	21.00
4250	3422	922	3.24	1047	4.22	1163	5.25	1264	6.24	1357	7.26	1447	8.49	1532	9.82	1613	11.20	1759	13.90	1894	16.60	2019	19.40	2136	22.20
4500	3623	961	3.72	1080	4.76	1193	5.83	1294	6.91	1385	7.95	1471	9.11	1555	10.50	1634	11.90	1781	14.80	1914	17.60	2038	20.50	2155	23.40
4750	3824	1001	4.24	1114	5.34	1224	6.46	1324	7.62	1413	8.72	1497	9.84	1578	11.10	1656	12.60	1803	15.70	1935	18.60	2058	21.70	2174	24.70
5000	4026	1040	4.82	1150	5.98	1256	7.15	1354	8.36	1443	9.56	1525	10.70	1603	11.90	1680	13.40	1824	16.50	1957	19.70	2079	22.80	2194	26.00
5250	4227	1080	5.45	1188	6.68	1288	7.90	1384	9.15	1473	10.40	1554	11.60	1630	12.90	1704	14.20	1846	17.40	1979	20.80	2101	24.10	2215	27.40
5500	4428	1121	6.14	1226	7.44	1321	8.70	1416	10.00	1503	11.30	1583	12.70	16											

Size 30, A43- -30 - - F100FG

SWSI
 Outlet Area - 1.5960 sq. ft. inside
 Wheel Diameter - 29.625 in.
 Wheel Circumference - 7.756 ft.
 Inlet Diameter - 17 in. I.D.

CFM	Outlet Velocity FPM	Static Pressure																							
		1"		2"		3"		4"		5"		6"		7"		8"		10"		12"		14"		16"	
		RPM	BHP	RPM	BHP	RPM	BHP	RPM	BHP	RPM	BHP	RPM	BHP	RPM	BHP	RPM	BHP	RPM	BHP	RPM	BHP	RPM	BHP	RPM	BHP
1800	1128	495	0.59	660	1.18	790	1.84	902	2.56	1001	3.33	1091	4.16												
2100	1316	513	0.69	675	1.37	803	2.08	914	2.85	1012	3.68	1101	4.55	1183	5.47	1260	6.44								
2400	1504	532	0.81	691	1.57	817	2.35	926	3.17	1024	4.05	1112	4.98	1194	5.95	1270	6.96	1411	9.11						
2700	1692	555	0.98	709	1.78	833	2.63	940	3.53	1036	4.46	1124	5.44	1205	6.46	1281	7.53	1421	9.77	1548	12.20				
3000	1880	579	1.19	727	1.98	850	2.94	956	3.90	1050	4.90	1137	5.93	1218	7.01	1293	8.13	1432	10.50	1558	13.00	1675	15.60	1783	18.30
3300	2068	604	1.41	746	2.22	868	3.26	972	4.30	1066	5.37	1151	6.47	1231	7.60	1306	8.76	1444	11.20	1569	13.80	1685	16.50	1793	19.40
3600	2256	630	1.66	768	2.52	886	3.57	990	4.72	1082	5.86	1166	7.03	1245	8.23	1319	9.45	1456	12.00	1581	14.70	1696	17.50	1804	20.50
3900	2444	656	1.96	791	2.88	905	3.90	1008	5.14	1099	6.37	1183	7.61	1261	8.88	1334	10.20	1469	12.80	1593	15.60	1708	18.60	1815	21.60
4200	2632	683	2.29	816	3.30	925	4.29	1026	5.55	1117	6.90	1200	8.22	1277	9.57	1349	10.90	1484	13.70	1606	16.60	1720	19.70	1827	22.80
4500	2820	713	2.66	840	3.73	947	4.78	1044	6.00	1135	7.42	1218	8.86	1294	10.30	1366	11.70	1498	14.70	1620	17.70	1734	20.80	1840	24.10
4800	3008	743	3.08	866	4.20	971	5.35	1064	6.51	1153	7.95	1236	9.49	1311	11.00	1383	12.50	1514	15.60	1635	18.80	1747	22.00	1853	25.40
5100	3195	775	3.54	891	4.72	995	5.96	1086	7.14	1172	8.52	1253	10.10	1330	11.80	1400	13.40	1531	16.60	1650	19.90	1762	23.30	1866	26.80
5400	3383	807	4.05	917	5.30	1020	6.61	1110	7.86	1192	9.18	1272	10.80	1347	12.50	1418	14.20	1548	17.60	1666	21.10	1777	24.60	1881	28.20
5700	3571	838	4.61	944	5.93	1045	7.29	1134	8.65	1214	9.97	1291	11.50	1366	13.20	1436	15.00	1565	18.70	1683	22.30	1793	26.00	1896	29.70
6000	3759	871	5.22	972	6.61	1070	8.03	1158	9.49	1238	10.90	1312	12.30	1385	14.00	1454	15.90	1583	19.70	1700	23.50	1809	27.30	1911	31.20
6300	3947	903	5.89	1001	7.35	1096	8.83	1183	10.40	1262	11.80	1335	13.30	1405	14.90	1473	16.80	1601	20.80	1718	24.80	1826	28.80	1928	32.80
6600	4135	936	6.62	1032	8.16	1122	9.69	1208	11.30	1286	12.90	1358	14.40	1426	15.90	1492	17.80	1619	21.80	1736	26.10	1844	30.20	1944	34.40
6900	4323	969	7.41	1063	9.03	1149	10.60	1234	12.30	1311	14.00	1382	15.60	1449	17.20	1513	18.80	1638	22.90	1754	27.30	1861	31.70		
7200	4511	1002	8.27	1094	9.97	1177	11.60	1259	13.30	1336	15.10	1407	16.80	1473	18.50	1535	20.10	1657	24.10	1772	28.50	1880	33.20		
7500	4699	1036	9.20	1126	11.00	1205	12.70	1285	14.40	1361	16.30	1431	18.10	1497	19.80	1559	21.60	1677	25.30	1790	29.80				
7800	4887	1070	10.20	1158	12.10	1235	13.80	1312	15.70	1387	17.50	1456	19.40	1521	21.30	1582	23.10	1698	26.70	1809	31.20				
8100	5075	1104	11.30	1190	13.20	1265	15.10	1339	16.90	1412	18.80	1481	20.80	1546	22.80	1607	24.70	1720	28.40	1829	32.70				
8400	5263	1138	12.40	1222	14.40	1296	16.40	1367	18.30	1438	20.30	1506	22.30	1571	24.30	1631	26.40	1744	30.20	1850	34.30				
8700	5451	1173	13.70	1255	15.70	1328	17.80	1395	19.70	1465	21.80	1532	23.80	1596	26.00	1656	28.10	1768	32.10						
9000	5639	1207	15.00	1287	17.10	1359	19.20	1425	21.30	1492	23.40	1558	25.50	1621	27.60	1681	29.80								
9300	5827	1242	16.40	1320	18.50	1391	20.80	1456	22.90	1520	25.00	1584	27.20	1647	29.40	1706	31.70								
9600	6015	1277	17.90	1353	20.10	1423	22.40	1486	24.60	1548	26.80	1611	29.00	1673	31.30	1731	33.60								
9900	6203	1312	19.50	1386	21.70	1455	24.10	1518	26.40	1577	28.70	1638	31.00	1699	33.30										
10200	6391	1347	21.20	1420	23.50	1487	25.90	1549	28.30	1607	30.60	1666	33.00												
10500	6579	1382	22.90	1453	25.30	1520	27.80	1581	30.30	1638	32.70														
10800	6767	1417	24.80	1487	27.30	1552	29.80	1613	32.40																
11100	6955	1452	26.80	1521	29.30	1585	31.90																		

Size 33, A43- -33 - - F100FG

SWSI
 Outlet Area - 2.061 sq. ft. inside
 Wheel Diameter - 33.000 in.
 Wheel Circumference - 8.639 ft.
 Inlet Diameter - 19 in. I.D.

CFM	Outlet Velocity FPM	Static Pressure																							
		1"		2"		3"		4"		5"		6"		7"		8"		10"		12"		14"		16"	
		RPM	BHP	RPM	BHP	RPM	BHP	RPM	BHP	RPM	BHP	RPM	BHP	RPM	BHP	RPM	BHP	RPM	BHP	RPM	BHP	RPM	BHP	RPM	BHP
2100	1019	439	0.68	588	1.39	706	2.18	806	3.05	895	3.99														
2400	1164	451	0.79	598	1.57	715	2.41	814	3.33	903	4.32	983	5.37	1058	6.48										
2700	1310	465	0.90	609	1.76	724	2.66	823	3.64	911	4.68	991	5.78	1065	6.94	1134	8.15								
3000	1456	479	1.02	621	1.96	735	2.93	832	3.96	920	5.06	999	6.21	1072	7.42	1141	8.68	1267	11.30						
3300	1601	495	1.19	634	2.17	746	3.22	842	4.32	929	5.46	1008	6.67	1081	7.93	1149	9.24	1274	12.00	1388	14.90				
3600	1747	513	1.39	647	2.38	758	3.52	853	4.69	939	5.90	1017	7.15	1090	8.47	1157	9.83	1282	12.70	1396	15.70	1500	18.90	1598	22.30
3900	1892	531	1.60	661	2.59	771	3.83	865	5.07	949	6.35	1027	7.68	1099	9.04	1166	10.50	1290	13.40	1403	16.60	1508	19.90	1605	23.30
4200	2038	549	1.84	675	2.85	784	4.15	877	5.48	961	6.83	1037	8.22	1109	9.65	1176	11.10	1299	14.20	1412	17.40	1515	20.80	1613	24.40
4500	2183	567	2.10	691	3.16	797	4.46	890	5.90	973	7.32	1048	8.78	1119	10.30	1186	11.80	1308	15.00	1420	18.30	1524	21.90	1620	25.50
4800	2329	586	2.39	708	3.53	810	4.79	903	6.33	985	7.84	1060	9.37	1130	10.90	1196	12.50	1318	15.80	1429	19.30	1532	22.90	1629	26.70
5100	2475	606	2.71	726	3.93	825	5.17	916	6.73	998	8.37	1072	9.97	1142	11.60	1207	13.30	1328	16.70	1439	20.30	1541	24.00	1637	27.80
5400	2620	626	3.06	743	4.36	840	5.62	929	7.16	1011	8.90	1085	10.60	1154	12.30	1219	14.00	1338	17.60	1448	21.30	1550	25.10	1646	29.10
5700	2766	648	3.46	761	4.81	857	6.15	943	7.63	1024	9.41	1098	11.20	1166	13.00	1231	14.80	1349	18.50	1459	22.40	1560	26.30	1655	30.40
6000	2911	671	3.88	780	5.29	874	6.72	958	8.16	1037	9.94	1111	11.90	1179	13.80	1243	15.70	1361	19.50	1469	23.50	1570	27.50	1665	31.70
6300	3057	693	4.35	798	5.81	892	7.34	974	8.79	1051	10.50	1124	12.50	1192	14.50	1256	16.50	1373	20.50	1480	24.60	1580	28.80	1675	33.10
6600	3202	716	4.85	817	6.38	910	7.98	990	9.51	1065	11.20	1137	13.10	1205	15.20	1269	17.40	1385	21.50	1492	25.80	1591	30.10		
6900	3348	739	5.39	836	6.98	928	8.65	1008	10.30	1081	11.90	1151	13.80	1218	16.00	1282	18.20	1398	22.60	1504	26.90	1603	31.40		
7200	3493	763	5.97	856	7.64	946	9.35	1025	11.10	1097	12.70	1166	14.60	1232	16.70	1295	19.00	1411	23.60	1516	28.20	1614	32.80		
7500	3639	786	6.60	876	8.33	964	10.10	1043	11.90	1114	13.70	1181	15.40	1246	17.60	1308	19.90	1							

Temperature/Altitude Applications

When a fan operates in ambient conditions, generally it is handling standard air at 70°F, 29.92" barometric pressure, weighing 0.075 lbs./cu. ft. For an application where the fan operates at other than ambient conditions (temperature, altitude, or both), correction factors must be applied to the selection of the fan. In addition, the standard construction of the fan must be modified.

Correction factors for temperatures and altitudes are provided in Table 1. When a fan operates at other than ambient conditions, the correction factors in Table 1 will be required to correct static pressure and horsepower.

Table 2 shows the maximum safe operating speeds for each size fan wheel.

At high temperatures, these maximum safe operating speeds should be derated. Table 3 provides maximum safe speed correction factors by temperature and material construction.

An example on the use of these tables appears at the bottom of this page.

Table 1 Altitude/Temperature Correction Factors

Temp. ① (°F)	-50	-25	0	25	50	70	100	125	150	175	200
Factor	0.77	0.82	0.87	0.91	0.96	1.00	1.06	1.10	1.15	1.20	1.25

Alt. ② (Ft.)	0	1000	2000	3000	4000	5000	6000	7000	8000	9000	10000	11000	12000
Factor	1.00	1.04	1.08	1.12	1.16	1.20	1.25	1.30	1.35	1.40	1.46	1.51	1.57

Above table has inverted values. Actual density is the reciprocal of the above values.

① At sea level.

② At 70°F.

For corrections involving both temperature and altitude, correction factors should be multiplied.

Example: 150°F at 7000 ft.

Temperature factor 1.15 x altitude factor 1.30 = 1.50 combined correction factor.

Table 2 Maximum Safe Speeds @ 70°F

SERIES 42	
Size	Max. Speed
10	4000
12	4000
14	3600

Maximum Operating Temperature: 200°F (Arrg. 4)
250°F (Arrg. 10)

SERIES 43	
Size	Max. Speed
16	3667
19	2995
23	2532
26	2193
30	1934
33	1736

Table 3 Maximum Safe Speed Correction Factors*

Temp.	0° F	70°	100°	150°	175°	200°	225°	250°
FRP	1.00	1.00	1.00	.98	.945	.91	.82	.70

*To correct maximum safe operating speeds (Table 2) for high temperatures, multiply those speeds by correction factors from Table 3.

Use of Altitude – Temperature Correction Table

First select size, RPM and BHP of the blower needed.

If temperature or altitude is involved, correct to standard air. Example: Assume the required performance to be 10,200 CFM at 6.15" SP 175°F and 2000 feet altitude.

1. Temperature factor 1.20 x altitude factor 1.08 = 1.30 combined correction factor.
2. 6.15" SP x 1.30 = 8" SP for 70°F at sea level.
3. A Series 43, size 33" belt drive radial centrifugal, selected from the rating tables (page 11) for the new condition shows 10,200 CFM at 8" SP, 1451 RPM and 31.5 BHP.
4. Correct the horsepower and static pressure in item 3 to non-standard performance by dividing by factor: 8" SP divided by 1.30 = 6.15" SP; 31.5 BHP divided by 1.30 = 24.23 BHP.
5. Check the maximum safe speed. Maximum speed at 70°F, for fan size 33", 1736 RPM. Using the maximum safe speed factor table for fiberglass construction yields a safe speed factor of .945. The maximum safe speed is 1736 x .945 = 1640 RPM; thus operation at 1451 RPM at 175°F is satisfactory.
6. Final performance of the unit at the assumed conditions: 10,200 CFM at 6.15" SP, 1451 RPM, 24.23 BHP at 175°F and 2,000 feet altitude.



Corrosion Resistance Guide

Temperature values shown are for immersion or condensate contact applications. Where temperature values are shown, resin is suitable for hood and duct type applications for the full operating temperature range of the product. See product specifications for materials of construction and maximum operating temperature limits.

Environment	Hetron 693 Ashland F.	6694 Reichold F.	510A Dow F.	Environment	Hetron 693 Ashland F.	6694 Reichold F.	510A Dow F.	Environment	Hetron 693 Ashland F.	6694 Reichold F.	510A Dow F.
ACIDS				ALKALIES (Synthetic Veil)				SALTS (cont'd.)			
Acetic to 10%	180	200	210	Ammonium Bicarbonate to 50%	140	\$170	160	Sodium Ferricyanide	220	220	210
Acetic to 50%	90	160	180	Ammonium Carbonate	120	\$140	150	Sodium Fluoride	-	\$180	\$180
Acetic to 100%		NR	NR	Ammonium Hydroxide to 5%	\$90	\$180	\$180	Sodium Nitrate	220	220	210
Acrylic to 25%	-	100	100	Ammonium Hydroxide to 10%	\$90	\$170	\$150	Sodium Nitrite		220	NR
Benzene Sulfonic to 25%	180	210	150	Ammonium Hydroxide to 29%	NR	\$100	\$100	Sodium Silicate PH less than 1	160	210	NR
Benzene Sulfonic 25% up	90	210	NR	Barium Carbonate	180	\$240	210	Sodium Sulfate	180	240	210
Benzoic	250	220	210	Barium Hydroxide to 10%	-	\$170	150	Sodium Sulfite	-	220	210
Boric	180	220	210	Calcium Hydroxide to 15%	160	\$210	\$180	Stannic Chloride	*180	*220	*210
Butyric to 50%	150	150	210	Magnesium Carbonate	160	\$210	180	Stannous Chloride	*200	*220	*210
Butyric 50% up	-	100	80	Potassium Bicarbonate to 10%	90	\$170	\$150	Zinc Chloride	200	*220	*210
Carbonic	160	220	NR	Potassium Carbonate to 10%	90	\$180	\$150	Zinc Nitrate	180	220	210
Chloroacetic to 25%	NR	*180	*150	Potassium Hydroxide to 25%	NR	\$120	\$150	Zinc Sulfite	150	220	NR
Chloroacetic 25% to 50%	NR	*150	*120	Sodium Bicarbonate to 10%	140	\$210	\$180				
Chromic to 5%	100	110	150	Sodium Carbonate to 35%	90	\$180	\$180	SOLVENTS			
Chromic to 10% to 20%	-	NR	150	Sodium Hydroxide to 10%	NR	\$160	\$180	Acetone to 10%	NR	180	180
Citic	*200	*220	*210	Sodium Hydroxide to 25%	NR	\$160	\$180	Benzene	90	80	NR
Fluoboric	*\$90	*\$220	*\$210	Sodium Sulfide	90	\$220	\$210	Carbon Disulfide	NR	NR	NR
Gluosilicic up to 10%	\$100	\$150	\$180	Trisodium Phosphate to 50%	-	\$175	210	Carbon Tetrachloride	90 VAPOR	110	150
Formic up to 10%	200	150	180					Chlorobenzene	NR	NR	NR
Gluconic to 50%	120	180	180	SALTS				Ethyl Acetate	NR	NR	NR
Hydrobromic to 25%	*160	*170	*180	Aluminum Chloride	*120	*240	*210	Ethyl Chloride	90 VAPOR	NR	NR
Hydrochloric to 15%	*230	*210	*180	Aluminum Potassium Sulfate	160	240	210	Ethylene Dibromide	NR	NR	NR
Hydrocyanic to 10%	200	170	210	Aluminum Sulfate	250	240	210	Ethylene Glycol	250	220	210
Hydrofluoric to 10%	***\$100	***\$150	***\$150	Ammonium Chloride	*200	*220	*210	n-Heptane	120	210	210
Hydrofluorsilicic up to 10%	*\$100	*\$150	*\$180	Ammonium Nitrate	200	220	220	Hexane	-	150	160
Hypochlorous to 20%	90	110	NR	Ammonium Persulfate	150	200	180	Methyl Ethyl Ketone to 10%	NR	80	NR
Lactic	*200	*220	*210	Ammonium Persulfate, saturate	150	NR	NR	Naphtha	200	210	180
Maleic	170	210	210	Ammonium Sulfate	200	220	220	Naphthalene	130	220	210
Nitric to 5%	200	170	150	Aniline Sulfate to 25%	150	220	210	Tetrachloroethylene	NR	100	80
Nitric 5% to 20%	-	140	120	Aniline Sulfate, saturated	150	220	NR	Toluene	90	NR	80
Oleic	200	220	210	Barium Chloride	200	240	210	Xylene	90	80	80
Oxalic	*220	*220	*210	Barium Sulfide	NR	\$210	180				
Perchloric to 10%	H&D	**150	**150	Calcium Chlorate	180	220	220	BLEACHES			
Phosphoric	*220	*\$210	*\$210	Calcium Chloride	250	240	220	Calcium Chlorate	180	220	220
Phosphoric, super	-	*\$210	*\$210	Calcium Sulfate	*200	*240	*210	Calcium Hypochlorite	100	NR	\$160
Phthalic Anhydride	*150	*210	*210	Copper Chloride	*250	*220	*220	Chlorine Dioxide up to 15%	-	160	*200
Picric to 10%	100	170	NR	Copper Cyanide	90	\$220	210	Chlorine Water	*125	*210	*200
Silicic	-	220	NR	Copper Fluoride	NR	\$170	NR	Hydrogen Peroxide to 30%	120	100	150
Stearic	200	220	210	Copper Sulfate	250	240	210	Sodium Chlorate	90	210	210
Sulfamic to 25%	160	150	NR	Ferric Chloride	*250	*220	*210	Sodium Hypochlorite to 15%	NR	125	\$180
Sulfuric to 25%	*200	*220	*210	Ferric Nitrate	170	220	210				
Sulfuric to 50%	*200	*200	*180	Ferric Sulfate	200	220	210	OTHERS			
Sulfuric to 70%	*150	*180	*100	Ferrous Chloride	*220	*220	*210	Alum. Chlorohydroxide to 50%	-	220	210
Sulfuric to 80%	NR	80	NR	Ferrous Nitrate	160	220	210	Ammonium Phosphate	150	210	210
Sulfurous to 10%	90	110	120	Ferrous Sulfate	220	220	210	Aqua Regia	NR	*80	NR
Tannic	200	220	210	Lead Acetate	160	220	210	Detergents	120	170	150
Tartaric	220	220	210	Magnesium Chloride	220	240	210	Glycerine	200	220	210
Trichloroacetic to 50%	*90	*220	*200	Magnesium Hydroxide	-	\$210	210	Kerosene	120	210	180
				Magnesium Sulfate	200	210	210	Photographic Solutions	-	80	NR
ALCOHOLS				Mercuric Chloride	*210	*220	*210	Perchloroethylene	NR	100	80
Amyl	200	210	120	Mercurous Chloride	210	220	210	Sodium Tetraborate	180	\$210	180
Benzyl	NR	100	NR	Nickel Chloride	220	220	210	Sodium Tripolyphosphate	125	210	210
Butyl	190	150	120	Nickel Nitrate	220	220	210	Sodium Xylene Sulfonate	-	170	160
Ethyl	90	120	80	Nickel Sulfate	220	220	210	Sorbitol Solutions	180	220	160
Methyl	90	80	NR	Potassium Chloride	200	240	210	Urea	90	170	150
				Potassium Dichromate	200	220	210	Urea-Ammonium-Nitrate	-	120	120
GASES AND VAPORS				Potassium Ferricyanide	200	220	210	Fertilizer Fumes	100	120	150
Ammonia, Dry	90	170	100	Potassium Nitrate	200	220	210	Shell-D-D	NR	100	NR
Ammonia, Wet	90	NR	NR	Potassium Permanganate	150	210	210	Steam Vapor	180	210	180
Bromine, Wet	90	*100	NR	Potassium Persulfate	90	220	210				
Carbon Dioxide	250	250	250	Potassium Sulfate	200	240	210				
Carbon Monoxide	200	250	250	Silver Nitrate	200	220	210				
Chlorine, Dry	*200	*210	NR	Sodium Acetate	150	220	210				
Florine	-	NR	80	Sodium Bisulfate	200	220	210				
Hydrogen Fluoride, Vapor	*90	*\$180	*\$180	Sodium Chloride	200	240	180				
Hydrogen Sulfide to 5%	250	240	180	Sodium Chlorite to 10%	175	170	150				
Sulfur Dioxide, Dry	200	250	210	Sodium Cyanide	100	220	210				
Sulfur Dioxide, Wet	200	250	210	Sodium Dichromate	160	220	210				
Sulfur Trioxide, Wet	-	220	210								

Reference
C.R.G.11

NOTES: NR = Not Recommended S = Synthetic surfacing veil or mat required. Contact factory. "-" = No test data available

* Special shaft and hardware required, contact factory.

** Special design considerations required (explosive environment), contact factory.

*** Do not use HartKoate. Special shaft and hardware required, contact factory.

For environments not shown, or when temperatures exceed the maximum listed, contact factory.

Hydrocarbon fuel environments may require static grounding, contact factory.

Do not use HartKoate (Alum. Oxide) with Hydrofluoric acid.



Options and Accessories

Drain

Fiberglass half coupling assembled in housing, NPT female threaded fitting. 1" NPT on Series 43; sizes 30" and 33", 1/2" NPT on Series 42 and Series 43, sizes 16"-26".



Inspection Door

Allows periodic visual inspection of wheel – fastened with stainless steel bolts and gasketed for tight seal. Available for Series 43.

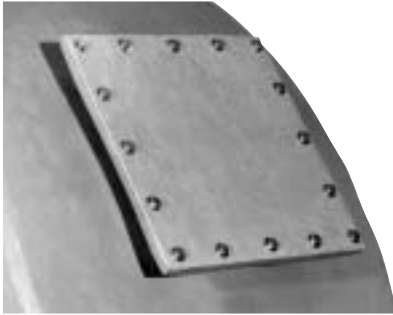

Flanged Inlet

Fiberglass inlet flange is available. Flanges are drilled upon request. Flanged and drilled inlet is required when inlet control damper is furnished.

Disconnect Switch

On-off switch mounted to the unit to provide safety during maintenance. Series 43 units.

Inlet Boxes

Solid fiberglass construction. Inlet box improves entry conditions and minimizes losses which are generally associated with duct elbows at the fan inlet. Inlet boxes are designed for specific applications. Contact factory.

Arrangement 1 Sub-Base

Common structural support for Arrangement 1 fan and motor. Specify motor mounting position. Epoxy coated steel. Series 43 only.

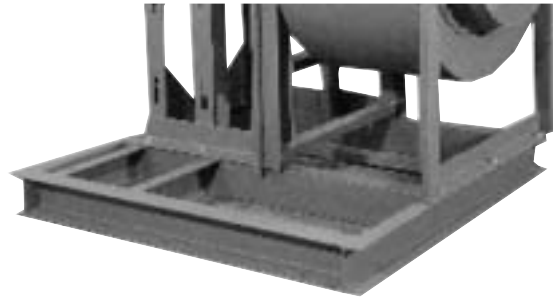

Vibration Isolators

Rubber-in-shear or spring type isolators available on all models.

Drive Guards

Encloses the drive assembly while permitting circulation of ambient air. Standard features include: tach opening, belt tension openings and adjustable length.



Shaft Guard
Arrangement 9 or 1

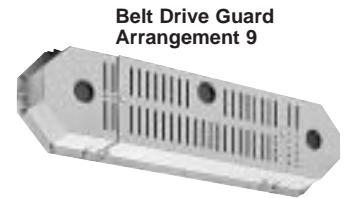

Belt Drive Guard
Arrangement 9

Inlet and Outlet Guards

Spiral ring guard offers protection on inlet side and a wire mesh guard can be furnished for the outlet side. Guards are epoxy coated steel.

Combination Drive Guard and Weather Cover

Covers motor and shaft sheaves as well as belts. Combines guarding the drive as well as protection from the weather. Epoxy coated steel. Specify fan arrangement.



Arrangement 9
Series 43



General Construction Options

Abrasive/Erosive Resistant Coating

HartKoate is an abrasive/erosive resistant coating developed by Hartzell Fan for application in environments where abrasive/erosive conditions may exist. HartKoate helps prevent premature deterioration of equipment in environments where uncoated fans may fail.

Impact resistant HartKoate is applied to a 50-60 mil thickness suitable for temperatures to 200°F.

HartKoate is particularly appropriate for use when water mist and/or abrasive particles exist in the airstream.

Contact your Hartzell representative for further details concerning the application of HartKoate coating to fiberglass fans in corrosive atmospheres.

Hi-Cor Construction

All airstream surfaces exposed to corrosive environment will be protected with a layer of Synthetic (Nexus) surfacing veil. An additional final coat of resin will be applied for extra corrosion resistance.

When Hi-Cor construction is required, the factory should be consulted concerning the corrosive environment involved.

Electrically Grounded Fiberglass Fans

For applications in which fiberglass fans are handling gas fumes that are not only corrosive but also potentially explosive, the equipment should be specially constructed to control and remove static electricity. Interior airstream surfaces can be coated with a "carbon rich" resin coat and grounding straps secured from the side of the housing to the fan's steel base. All that remains to effectively ground the airstream is to ground the fan base at the time of installation.

ASTM D4167-97 Construction

(ASTM D4167-97, Standard Specification for Fiber-Reinforced Plastic Fans and Blowers) For corrosive systems where ASTM construction is specified this construction option adds: synthetic veil and electrostatically conductive surface coating applied to airstream housing and impeller surfaces, special nameplates, and special final dynamic balancing to fan.

**CONTACT YOUR LOCAL HARTZELL
REPRESENTATIVE FOR ASSISTANCE.
1-800-336-3267**

Heavy-Duty Control Dampers

Inlet Control Damper

Dampers are mounted on the blower's drilled inlet flange to both increase the efficiency of the system and permit control of air volume. Dampers are epoxy coated or stainless steel construction.

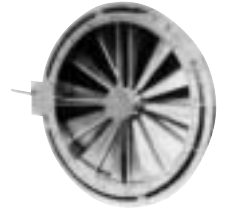

Outlet Dampers

Dampers are mounted directly on the blower outlet to control the volume of air delivered to the system. Opposed and parallel blade dampers are available in steel, stainless steel, coated steel and solid fiberglass.

Parallel Blade Type

Best suited for applications requiring accurate air volume in a range from wide open to 75% of wide open. Usually used for balancing the system or for modulated control when pressure drop is variable.



Opposed Blade Type

Best suited for control over a broad range of air volume with more precise control.

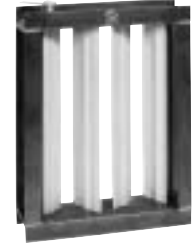

Both types of outlet control dampers are available in three classifications:

Class I – Maximum static pressure: 5" SP
Maximum velocity: 3900 FPM

Class II – Maximum static pressure: 8½" SP
Maximum velocity: 5100 FPM

Class III – Maximum static pressure: 20" SP
Maximum velocity: 6000 FPM

SAFETY ACCESSORIES, APPLICATION AND USE WARNING

The safe application and use of equipment supplied by Hartzell Fan, Inc. is the responsibility of the installer, the user, the owner, and the employer. Since the application and use of its equipment can vary greatly, Hartzell Fan, Inc. offers various product types, optional safety accessories, and sound performance data per laboratory tests. Hartzell Fan, Inc. sells its equipment with and without safety accessories, and accordingly, it can supply such safety accessories only upon receipt of an order. The need for safety accessories will frequently depend upon the type of system, fan location and operating procedures being employed. The proper protective safety accessories to meet company standards, local codes, and the requirements of the Occupational Safety and Health Act must be determined by the user since safety requirements vary depending on the location and use of the equipment. If applicable local conditions, standards, codes or OSHA rules require the addition of the safety accessories, the user should specify and obtain the required safety accessories from Hartzell Fan, Inc. and should not allow the operation of the equipment without them.

Owners, employers, users and installers should read "RECOMMENDED SAFETY PRACTICES FOR USERS AND INSTALLERS OF INDUSTRIAL AND COMMERCIAL FANS" published by the Air Movement Control Association International, Inc., 30 West University Drive, Arlington Heights, Illinois 60004. A copy of this publication is enclosed with each fan shipped from Hartzell Fan, Inc., and is available upon request at Hartzell's office in Piqua, Ohio 45356.

Please contact Hartzell Fan, Inc. or your local Hartzell representative for more information on product types, safety accessories, and sound performance estimates.

Remember, the selection of safety accessories and the safe application and use of equipment supplied by Hartzell Fan, Inc. is **your** responsibility.



Hartzell Warranty

LIMITED WARRANTIES

Hartzell represents to Buyer that any goods to be delivered hereunder will be produced in compliance with the requirements of the Fair Labor Standards Act of 1938 as amended.

Hartzell also warrants to Buyer its goods to be free from defects in workmanship and material under normal use and service for one (1) year after tender of delivery by Hartzell, plus six months allowance for shipment to approved stocking dealers and distributors. No warranty extends to future performance of goods and any claims for breach of warranty or otherwise accrues upon tender of delivery. The foregoing constitute Hartzell's sole and exclusive warranties and are in lieu of all other warranties, whether written, oral, express, implied or statutory.

LIMITATION OF LIABILITY FOR BREACH OF WARRANTY

Hartzell's obligation for any breach of warranty is limited to repairing or replacing, at its option, without cost to Buyer at its factory any goods which shall, within such a warranty period, be returned to it with transportation charges prepaid, and which its examination shall disclose to its satisfaction to have been defective. Any request for repair or replacement should be directed to Hartzell Fan, Inc., P.O. Box 919, Piqua, Ohio 45356. Hartzell will not pay for any repairs made outside its factory without its prior written consent. This does not apply to any such Hartzell goods which have failed as a result of faulty installation or abuse, or incorrect electrical connections or alterations, made by others, or use under abnormal operating conditions or misapplication of the goods.

LIMITATION OF LIABILITY

To the extent the above limitation of liability for breach of warranty is not applicable, the liability of Hartzell on any claim of any kind, including negligence, for any loss or damage arising out of or connected with, or resulting from the sale and purchase of the goods or services covered by these Terms and Conditions of Sale or from the performance or breach of any contract pertaining to such sale or purchase or from the design manufacture, sale, delivery, resale, installation, technical direction installation, inspection repair, operation or use of any goods or services covered by these Terms and Conditions shall, in no case exceed the price allocable to the goods or services which gave rise to the claim and shall terminate one year after tender of delivery of said goods or services, plus six months allowance for shipment to approved stocking dealers and distributors. In no event will Hartzell be responsible or liable for any labor or other incidental costs associated with the removal or replacement of defective products or materials.

In no event whether as a result of breach of contract, or warranty or alleged negligence, defects, incorrect advice or other causes, shall Hartzell be liable for special or consequential damages, including, but not limited to, loss of profits or revenue, loss of use of the equipment or any associated equipment, cost of substitute equipment, facilities or services, down time costs, or claims of customers of the Buyer for such damages. Hartzell neither assumes nor authorizes any person to assume for it any other liability in connection with the sale of its goods or services.

NO IMPLIED WARRANTIES OF MERCHANTABILITY OR FITNESS

HARTZELL DOES NOT WARRANT THAT SAID GOODS ARE OF MERCHANTABLE QUALITY OR THAT THEY ARE FIT FOR ANY PARTICULAR PURPOSE. THERE IS NO IMPLIED WARRANTY OF MERCHANTABILITY AND THERE IS NO IMPLIED WARRANTY OF FITNESS.



Propeller Fans



Cooling Tower &
Heat Exchanger Fans



Duct Fans



Duct Axial Fans



Vaneaxial Blowers



Cool Blast & Utility Fans



Steel Centrifugal Blowers



Roof Ventilators –
Steel & Fiberglass



Heating Equipment –
Gas & Steam



Fiberglass
Axial Flow Fans



Fiberglass Centrifugal
Blowers



Marine –
Mine Duty Blowers

Hartzell Fan, Inc., Piqua, Ohio 45356 • Plants in Piqua, Ohio and Portland, Indiana.