

Pressure Blowers

Series 07

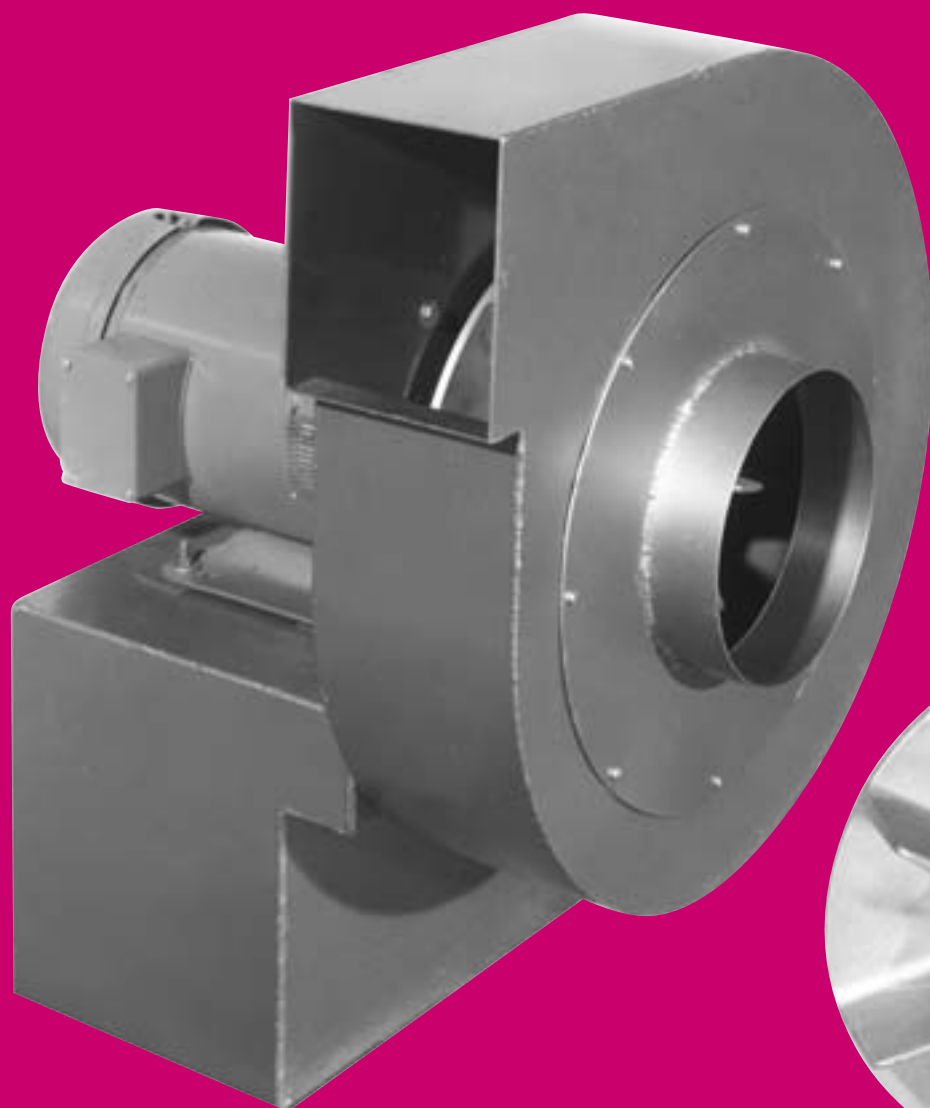

HARTZELL®

Hartzell Fan, Inc., Piqua, Ohio 45356
www.hartzellfan.com

Bulletin A-134-K August 2007

Pressure Blower (Direct Drive)



**Series 07
Arrangement 4**

ABS Certificate
of Design Assessment
Received

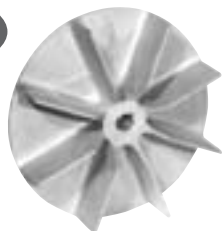

Radial-Blade Wheel

- **Application** – designed to meet general industrial air-moving requirements. Best suited for air laden with dust and grit. Pressure blowers work up to temperatures of 200°F.
- **Efficiency** – works economically up to static pressures of 14" W.G.
- **Performance** – operates smoothly from free air to block-off without excessive pulsation and vibration.
- **Construction** – heavy gauge, welded, hot-rolled steel fan scroll and base. Materials are the same for all static pressure ranges.

Features

- **Sizes** – 11", 12" and 14" wheel diameters.
- **Arrangement** – Available in Arrangement #4 and #10.
- **Rotation** – clockwise and counterclockwise.
- **Discharges** – available discharges shown on page 3. **Rotatable in field.**
- **Easy installation** – packaged unit, ready for installation.
- **Fan housing** – fan housing, scroll, is constructed of continuously welded 14 gauge hot rolled steel.
- **Arrangement 4 motor base** – motor base constructed of 10 gauge, welded, hot rolled steel.
- **Arrangement 10 drive assembly** – shafts are turned, ground and polished, keyed at both ends. Belts are oil, heat and static resistant type. Motor, drive, and bearings are readily accessible for ease in wiring, installation, adjustment and lubrication.
- **Wheel** – cast aluminum, flat-blade radial wheel with excellent self-cleaning characteristics. Prevents material buildup on and around the wheel. Dynamically balanced for smooth operation.
- **Motor** – open end, drip proof are standard. Totally enclosed fan cooled and other special motors can be furnished upon request.
- **Surface coatings** – standard coating is an industrial grade enamel.

Hartzell Model Code

A 0 7 - 4 - 1 4 - - 1 1 0 0 S T O P H 3

Type _____	A	0	7	-	4	-	1	4	-	-	1	1	0	0	S	T	O	P	H	3	Motor RPM/Phase
A – Production Item																					3 Phase
S – Stock Item																					1 Phase
Q – Special Quote																					2 = 3450
Product Series _____																					3 = 1750
Arrangement (centrifugals only) _____																					
Size (nominal wheel diameter, inches) _____																					
Class _____																					
Wheel Code _____																					
Wheel Width (entries represent percents) _____																					
Material of Construction _____																					
Motor Enclosure _____																					
Motor Horsepower _____																					

Motor Horsepower

Horsepower	1/4	1/3	1/2	3/4	1	1 1/2	2	3	5	7 1/2
Code Letter	D	E	F	G	H	I	J	K	L	M

Certificates of Design Assessment are issued by the American Bureau of Shipping. The assessment is a representation by the Bureau as to the degree of compliance the design exhibits with applicable sections of the Rules. The certificates, by itself, do not reflect that the products are Type Approved.

How to Use Model Code Index:

EXAMPLE:

Assume a required performance of 400 CFM at 2.5" S.P.W.G., at standard conditions is required. Reading Rating table on page 5, we find Series 07 Pressure Blower with a 14" wheel diameter with 100% wheel width. 419 CFM at 2.5" S.P., 1750 RPM, 5 HP.

Open, protected motor enclosure. Motor horsepower required is 1; therefore, horsepower code is "H." Motor RPM required is 1750; therefore, motor RPM code is "3."

NOTE: All other informational fields must be filled with hyphens/dashes (-) if they are not applicable to the fan being considered.

This bulletin lists Hartzell's complete line of Pressure Blowers and accessories. More than 70 Hartzell offices can provide specific performance and installation data to meet your requirements. Call your Hartzell representative for assistance. Visit our website (www.hartzellfan.com) or call toll-free for the name of your Hartzell representative.



Dimensions

Series 07 – Sizes 11", 12" and 14", Rotatable Housing

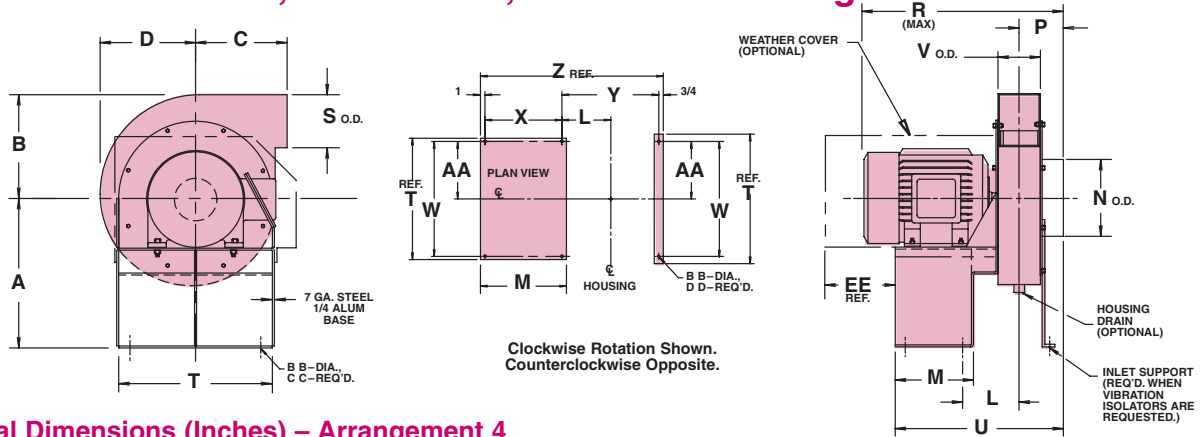

Principal Dimensions (Inches) – Arrangement 4

Fan Size	A	B	C	D	E	F	G	H	J	K
11	12 ¹ / ₈	8 ³ / ₄	7 ⁵ / ₈	8	8 ³ / ₈	11 ⁵ / ₈	7 ⁵ / ₈	7 ¹ / ₄	6 ⁷ / ₈	–
12	14 ¹ / ₈	9 ³ / ₄	8 ⁵ / ₈	9	9 ³ / ₈	13	8 ⁵ / ₈	8 ¹ / ₄	7 ⁷ / ₈	–
14	16 ¹ / ₈	11 ⁷ / ₈	11	11 ¹ / ₈	11 ¹ / ₂	16 ³ / ₁₆	10 ³ / ₄	10 ³ / ₈	10	1 ¹ / ₁₆

Fan Size	L	M	N	P	R	S	T	U	V	W	X	Y	Z	AA	BB	CC	DD	EE	MIN. MOTOR FRAME	MAX. MOTOR FRAME	MAX. WEIGHT IS LESS MOTOR WEIGHT & ACCESSORIES
11	5 ¹ / ₈	6 ⁷ / ₈	6 ³ / ₁₆	3 ¹⁵ / ₁₆	18 ⁷ / ₁₆	4	13	14 ¹⁵ / ₁₆	3 ¹ / ₂	11	4 ⁷ / ₈	7 ¹³ / ₁₆	14 ⁷ / ₁₆	5 ¹ / ₂	7 ¹ / ₁₆	4	6	5	56	145T	58
12	5 ³ / ₈	7 ³ / ₈	7 ³ / ₁₆	4 ³ / ₁₆	20	5	14 ¹ / ₂	15 ¹⁵ / ₁₆	4	12 ¹ / ₂	5 ³ / ₈	8 ⁹ / ₁₆	15 ⁷ / ₁₆	6 ¹ / ₄	7 ¹ / ₁₆	4	6	5 ¹ / ₄	56	184T	71
14	5 ⁵ / ₈	9 ³ / ₄	8 ³ / ₁₆	5 ¹ / ₁₆	24 ⁷ / ₈	7 ¹ / ₈	15 ¹ / ₂	19 ⁷ / ₁₆	5 ³ / ₄	13 ¹ / ₂	7 ³ / ₄	9 ⁷ / ₁₆	18 ¹⁵ / ₁₆	6 ³ / ₄	7 ¹ / ₁₆	4	6	6 ¹ / ₈	143T	213T	95

Note: Dimensions and specifications are subject to change. Certified prints are available.
 *Maximum fan weight is less motor and accessories.

Belt Drive

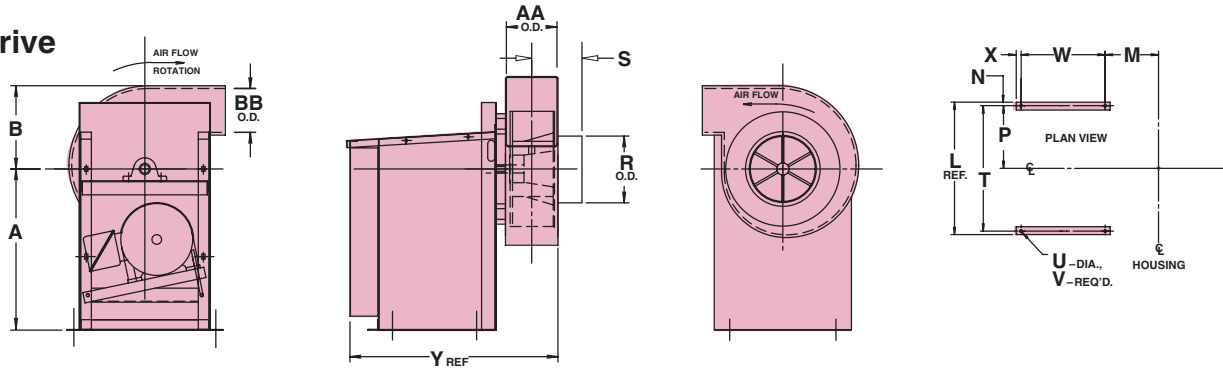

Principal Dimensions (Inches) – Arrangement 10

Fan Size	A	B	C	D	E	F	G	H	J
11	18 ¹ / ₁₆	8 ³ / ₄	7 ⁵ / ₈	8	8 ³ / ₈	11 ⁵ / ₈	7 ⁵ / ₈	7 ¹ / ₄	6 ⁷ / ₈
12	18 ¹ / ₁₆	9 ³ / ₄	8 ⁵ / ₈	9	9 ³ / ₈	13	8 ⁵ / ₈	8 ¹ / ₄	7 ⁷ / ₈
14	18 ¹ / ₁₆	11 ⁷ / ₈	11	11 ¹ / ₈	11 ¹ / ₂	16 ³ / ₁₆	10 ³ / ₄	10 ³ / ₈	10

Fan Size	L	M	N	P	R	S	T	U	V	W	X	Y	AA	BB	MAX. MOTOR FRAME	MAX. WEIGHT IS LESS MOTOR WEIGHT & ACCESSORIES
11	21 ¹ / ₄	6 ¹³ / ₃₂	3/4	9 ⁷ / ₈	6 ³ / ₁₆	3 ¹⁵ / ₁₆	19 ³ / ₄	9 ¹ / ₁₆	4	12	2	28 ¹¹ / ₃₂	3 ¹ / ₂	4	182T	85
12	21 ¹ / ₄	6 ²¹ / ₃₂	3/4	9 ⁷ / ₈	7 ³ / ₁₆	4 ³ / ₁₆	19 ³ / ₄	9 ¹ / ₁₆	4	12	2	28 ²⁷ / ₃₂	4	5	182T	90
14	21 ¹ / ₄	7 ¹⁷ / ₃₂	3/4	9 ⁷ / ₈	8 ³ / ₁₆	5 ¹ / ₁₆	19 ³ / ₄	9 ¹ / ₁₆	4	12	2	30 ¹⁹ / ₃₂	5 ³ / ₄	7 ¹ / ₈	182T	100

Fan Discharges

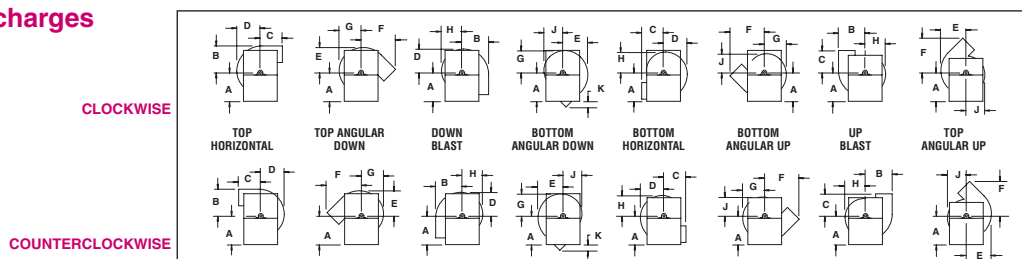

Performance Data, 100% Width

Rating Table – Series 07 (Belt Drive, Wheel Type I)

A07-0-11--1100ST _ _ _ _

Wheel Diameter: 11.125"
Wheel Circumference: 2.913"
Outlet Area: 0.097 Sq. Ft.

CFM	Outlet Velocity FPM	Static Pressure															
		1½"		3"		4½"		6"		8"		10"		12"		14"	
		RPM	BHP	RPM	BHP	RPM	BHP	RPM	BHP	RPM	BHP	RPM	BHP	RPM	BHP	RPM	BHP
80	825	1533	0.05	2144	0.13	2623	0.23										
120	1237	1591	0.06	2176	0.15	2639	0.25	3035	0.37	3498	0.55	3910	0.75				
160	1649	1662	0.08	2234	0.17	2682	0.28	3067	0.40	3518	0.59	3921	0.80	4288	1.03	4628	1.27
200	2062	1753	0.11	2304	0.21	2742	0.32	3118	0.45	3559	0.64	3953	0.86	4312	1.09	4646	1.34
240	2474	1855	0.14	2378	0.25	2813	0.37	3182	0.51	3614	0.71	4000	0.93	4353	1.17	4680	1.43
280	2887	1957	0.17	2472	0.30	2885	0.44	3253	0.58	3679	0.79	4058	1.01	4405	1.26	4727	1.53
320	3299	2061	0.22	2574	0.36	2971	0.51	3325	0.66	3750	0.88	4125	1.12	4467	1.37	4784	1.64
360	3711	2176	0.27	2676	0.42	3071	0.59	3408	0.76	3821	0.99	4197	1.24	4536	1.50	4849	1.78
400	4124	2301	0.33	2778	0.50	3173	0.68	3506	0.86	3900	1.12	4267	1.38	4608	1.65	4919	1.94
440	4536	2434	0.41	2881	0.59	3275	0.78	3609	0.97	3994	1.25	4345	1.53	4678	1.82	4991	2.11
480	4948	2571	0.50	2991	0.68	3377	0.89	3710	1.10	4094	1.39	4436	1.69	4756	2.00	5062	2.32
520	5361	2715	0.60	3110	0.80	3479	1.01	3812	1.24	4197	1.55	4535	1.87	4846	2.20	5140	2.53
560	5773	2863	0.72	3236	0.93	3586	1.15	3914	1.39	4298	1.72	4638	2.06	4944	2.40		
600	6186	3015	0.85	3367	1.07	3698	1.31	4017	1.56	4400	1.91	4739	2.26	5046	2.62		
640	6598	3169	1.00	3502	1.23	3819	1.48	4122	1.74	4503	2.11	4841	2.48	5148	2.86		
680	7010	3326	1.17	3641	1.41	3945	1.67	4233	1.94	4605	2.33	4943	2.72				

A07-0-12--1100ST _ _ _ _

Wheel Diameter: 12.5"
Wheel Circumference: 3.272"
Outlet Area: 0.139 Sq. Ft.

CFM	Outlet Velocity FPM	Static Pressure															
		1½"		3"		4½"		6"		8"		10"		12"		14"	
		RPM	BHP	RPM	BHP	RPM	BHP	RPM	BHP	RPM	BHP	RPM	BHP	RPM	BHP	RPM	BHP
120	863	1329	0.06														
180	1295	1369	0.08	1883	0.17	2292	0.29	2642	0.44								
240	1727	1435	0.11	1923	0.21	2317	0.32	2657	0.47	3056	0.69	3412	0.94				
300	2158	1524	0.14	1983	0.26	2361	0.39	2689	0.52	3078	0.74	3427	0.99	3745	1.27	4039	1.57
360	2590	1630	0.19	2057	0.32	2420	0.47	2738	0.62	3115	0.83	3455	1.08	3767	1.35	4056	1.65
420	3022	1744	0.25	2148	0.40	2492	0.56	2800	0.74	3166	0.97	3496	1.21	3800	1.47	4085	1.77
480	3453	1876	0.33	2254	0.49	2576	0.66	2871	0.86	3227	1.12	3549	1.38	3846	1.65	4123	1.94
540	3885	2000	0.43	2361	0.60	2676	0.79	2953	0.99	3297	1.28	3612	1.58	3902	1.87	4173	2.17
600	4317	2124	0.54	2479	0.73	2783	0.93	3049	1.14	3376	1.45	3682	1.78	3966	2.11	4231	2.43
660	4748	2254	0.67	2611	0.89	2889	1.09	3154	1.32	3465	1.64	3760	1.98	4037	2.34	4297	2.71
720	5180	2391	0.82	2739	1.06	3005	1.28	3260	1.53	3567	1.86	3846	2.21	4114	2.59	4369	2.99
780	5612	2537	1.00	2862	1.27	3135	1.51	3369	1.76	3675	2.12	3945	2.48	4200	2.86		
840	6043	2686	1.20	2986	1.49	3267	1.76	3488	2.02	3780	2.39	4050	2.78				
900	6475	2837	1.43	3115	1.75	3392	2.04	3619	2.32	3889	2.70	4158	3.12				
960	6906	2989	1.69	3248	2.03	3515	2.35	3751	2.66	4006	3.04						
1020	7338	3141	1.98	3386	2.34	3639	2.69	3877	3.02								

A07-0-14--1100ST _ _ _ _

Wheel Diameter: 13.5"
Wheel Circumference: 3.534"
Outlet Area: 0.285 Sq. Ft.

CFM	Outlet Velocity FPM	Static Pressure															
		1½"		3"		4½"		6"		8"		10"		12"		14"	
		RPM	BHP	RPM	BHP	RPM	BHP	RPM	BHP	RPM	BHP	RPM	BHP	RPM	BHP	RPM	BHP
100	351	1246	0.08														
200	702	1279	0.11	1777	0.26	2164	0.43	2492	0.63								
300	1053	1339	0.16	1817	0.33	2196	0.53	2518	0.75	2894	1.08	3226	1.43	3527	1.81		
400	1404	1409	0.22	1876	0.42	2242	0.65	2558	0.90	2928	1.26	3256	1.65	3554	2.06	3829	2.50
500	1754	1480	0.29	1946	0.54	2305	0.79	2610	1.07	2972	1.47	3295	1.89	3590	2.34	3862	2.82
600	2105	1561	0.37	2017	0.68	2375	0.96	2677	1.27	3029	1.70	3345	2.17	3634	2.65		
700	2456	1660	0.47	2088	0.82	2445	1.17	2748	1.50	3096	1.97	3405	2.47	3688	3.00		
800	2807	1774	0.60	2166	0.96	2517	1.40	2818	1.78	3167	2.28	3474	2.82				
900	3158	1890	0.76	2256	1.14	2589	1.59	2889	2.08	3237	2.65						
1000	3509	2005	0.95	2359	1.36	2669	1.81	2961	2.35	3308	3.05						
1100	3860	2123	1.16	2473	1.62	2761	2.09	3037	2.62								
1200	4211	2244	1.39	2590	1.92	2862	2.41	3122	2.94								
1300	4561	2365	1.66	2704	2.25	2974	2.79										
1400	4912	2487	1.96	2819	2.62												
1500	5263	2611	2.29	2936	3.03												
1600	5614	2737	2.67														

Performance certified for installation Type D: ducted inlet/ducted outlet.
Performance data is based on standard air conditions (0.075 #/ft.3) and constant speed.
Power ratings (BHP) excludes transmission losses.
Performance ratings do not include the effects of appurtenances (accessories).

To complete model code add material code ST, motor enclosure code, motor horsepower code, and motor speed code.
Refer to page 2 for additional model code information.



Performance Data

Rating Table – Series 07 (Direct Drive, Wheel Type I)

Size	Motor		Motor(Fan)		Peak Fan BHP	CUBIC FEET PER MINUTE vs. STATIC PRESSURE																Outlet Area sq. ft.	Wheel Dia. Inches	
	HP	Code	RPM	Code		0"	½"	1"	1½"	2"	2½"	3"	4"	5"	6"	7"	8"	9"	10"	11"				
11	½	E	1750	3	.19	407	349	285	199	63											.097	11⅛		
	1½	I	3450	2	1.47	765	736	711	685	656	625	553	463	377	267									
12	½	E	1750	3	.34		564	497	423	340	212										.139	12½		
	3	K	3450	2	2.96					1180	1077	1047	971	888	822	737	650	533	351					
14	1	H	1750	3	.82	1193	1056	912	779	631	419										.285	13½		
	5	L	3450	2	5.67					2143	2073	2000	1925	1782	1642	1515	1378	1197	979	766			511	
	7½	M	3450	2	6.27					2213	2143	2073	2000	1925	1782	1642	1515	1378	1197	979			766	511

Performance certified for Installation Type D: ducted inlet/ducted outlet.
Performance ratings do not include the effects of appurtenances (accessories).
Performance is based on standard air conditions and constant speed.

Options & Accessories



Arrangement 4 with Weather Cover

Accessories

- **Drain pipe coupling** – 1" pipe coupling welded to housing at its lowest point; female pipe has threaded plug.
- **Weather cover Arrangement 4** – combines guarding of motor and drive as well as providing protection from the weather.
- **Combination drive guard weather cover Arrangement 10** – covers motor, drive sheaves, shaft and bearings, as well as belts. Combines guarding of the drive as well as protection from the weather for arrangement 10.
- **Inlet and outlet guards** – spiral ring guard offers protection on inlet side and a wire mesh guard can be furnished for the outlet side.
- **Coatings** – epoxy, inorganic zinc and catalyzed coal tar epoxy coatings are available upon request.
- **Inlet and outlet flanges** – drilled or undrilled.

CAUTION: The drive assembly or the periphery of the wheel of a fan less than seven (7) feet above the floor or working level must be guarded to be in accordance with OSHA regulations.

SAFETY ACCESSORIES, APPLICATION AND USE WARNING

The safe application and use of equipment supplied by Hartzell Fan, Inc. is the responsibility of the installer, the user, the owner, and the employer. Since the application and use of its equipment can vary greatly, Hartzell Fan, Inc. offers various product types, optional safety accessories, and sound performance data per laboratory tests. Hartzell Fan, Inc. sells its equipment with and without safety accessories, and accordingly, it can supply such safety accessories only upon receipt of an order. The need for safety accessories will frequently depend upon the type of system, fan location and operating procedures being employed. The proper protective safety accessories to meet company standards, local codes, and the requirements of the Occupation Safety and Health Act must be determined by the user since safety requirements vary depending on the location and use of the equipment. If applicable local conditions, standards, codes or OSHA rules require the addition of the safety accessories, the user should specify and obtain the required safety accessories from Hartzell Fan, Inc. and should not allow the operation of the equipment without them.

Owners, employers, users and installers should read "RECOMMENDED SAFETY PRACTICES FOR USERS AND INSTALLERS OF INDUSTRIAL AND COMMERCIAL FANS" published by the Air Movement and Control Association International, Inc., 30 West University Drive, Arlington Heights, Illinois 60004. A copy of this publication is enclosed with each fan shipped from Hartzell Fan, Inc., and is available upon request at Hartzell's office in Piqua, Ohio 45356. Please contact Hartzell Fan, Inc. or your local Hartzell representative for more information on product types, safety accessories, and sound performance estimates.

Remember, the selection of safety accessories and the safe application and use of equipment supplied by Hartzell Fan, Inc. is **your** responsibility.



Hartzell Warranty

LIMITED WARRANTIES

Hartzell represents to Buyer that any goods to be delivered hereunder will be produced in compliance with the requirements of the Fair Labor Standards Act of 1938 as amended.

Hartzell also warrants to Buyer its goods to be free from defects in workmanship and material under normal use and service for one (1) year after tender of delivery by Hartzell, plus six months allowance for shipment to approved stocking dealers and distributors. No warranty extends to future performance of goods and any claims for breach of warranty or otherwise accrues upon tender of delivery. The foregoing constitute Hartzell's sole and exclusive warranties and are in lieu of all other warranties, whether written, oral, express, implied or statutory.

LIMITATION OF LIABILITY FOR BREACH OF WARRANTY

Hartzell's obligation for any breach of warranty is limited to repairing or replacing, at its option, without cost to Buyer at its factory any goods which shall, within such a warranty period, be returned to it with transportation charges prepaid, and which its examination shall disclose to its satisfaction to have been defective. Any request for repair or replacement should be directed to Hartzell Fan, Inc., P.O. Box 919, Piqua, Ohio 45356. Hartzell will not pay for any repairs made outside its factory without its prior written consent. This does not apply to any such Hartzell goods which have failed as a result of faulty installation or abuse, or incorrect electrical connections or alterations, made by others, or use under abnormal operating conditions or misapplication of the goods.

LIMITATION OF LIABILITY

To the extent the above limitation of liability for breach of warranty is not applicable, the liability of Hartzell on any claim of any kind, including negligence, for any loss or damage arising out of or connected with, or resulting from the sale and purchase of the goods or services covered by these Terms and Conditions of Sale or from the performance or breach of any contract pertaining to such sale or purchase or from the design manufacture, sale, delivery, resale, installation, technical direction installation, inspection repair, operation or use of any goods or services covered by these Terms and Conditions shall, in no case exceed the price allocable to the goods or services which gave rise to the claim and shall terminate one year after tender of delivery of said goods or services, plus six months allowance for shipment to approved stocking dealers and distributors.

In no event whether as a result of breach of contract, or warranty or alleged negligence, defects, incorrect advice or other causes, shall Hartzell be liable for special or consequential damages, including, but not limited to, loss of profits or revenue, loss of use of the equipment or any associated equipment, cost of substitute equipment, facilities or services, down time costs, or claims of customers of the Buyer for such damages. Hartzell neither assumes nor authorizes any person to assume for it any other liability in connection with the sale of its goods or services.

NO IMPLIED WARRANTIES OF MERCHANTABILITY OR FITNESS

HARTZELL DOES NOT WARRANT THAT SAID GOODS ARE OF MERCHANTABILITY QUALITY OR THAT THEY ARE FIT FOR ANY PARTICULAR PURPOSE. THERE IS NO IMPLIED WARRANTY OF MERCHANTABILITY AND THERE IS NO IMPLIED WARRANTY OF FITNESS.



Propeller Fans

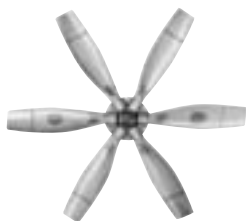

Cooling Tower & Heat Exchanger Fans



Duct Fans



Duct Axial Fans



Vaneaxial Blowers



Cool Blast & Utility Fans



Steel Centrifugal Blowers



Roof Ventilators - Steel & Fiberglass



Heating Equipment - Gas & Steam



Fiberglass Axial Flow Fans



Fiberglass Centrifugal Blowers



Marine - Mine Duty Blowers