

Steel In-Line Centrifugal Fans

Series 04

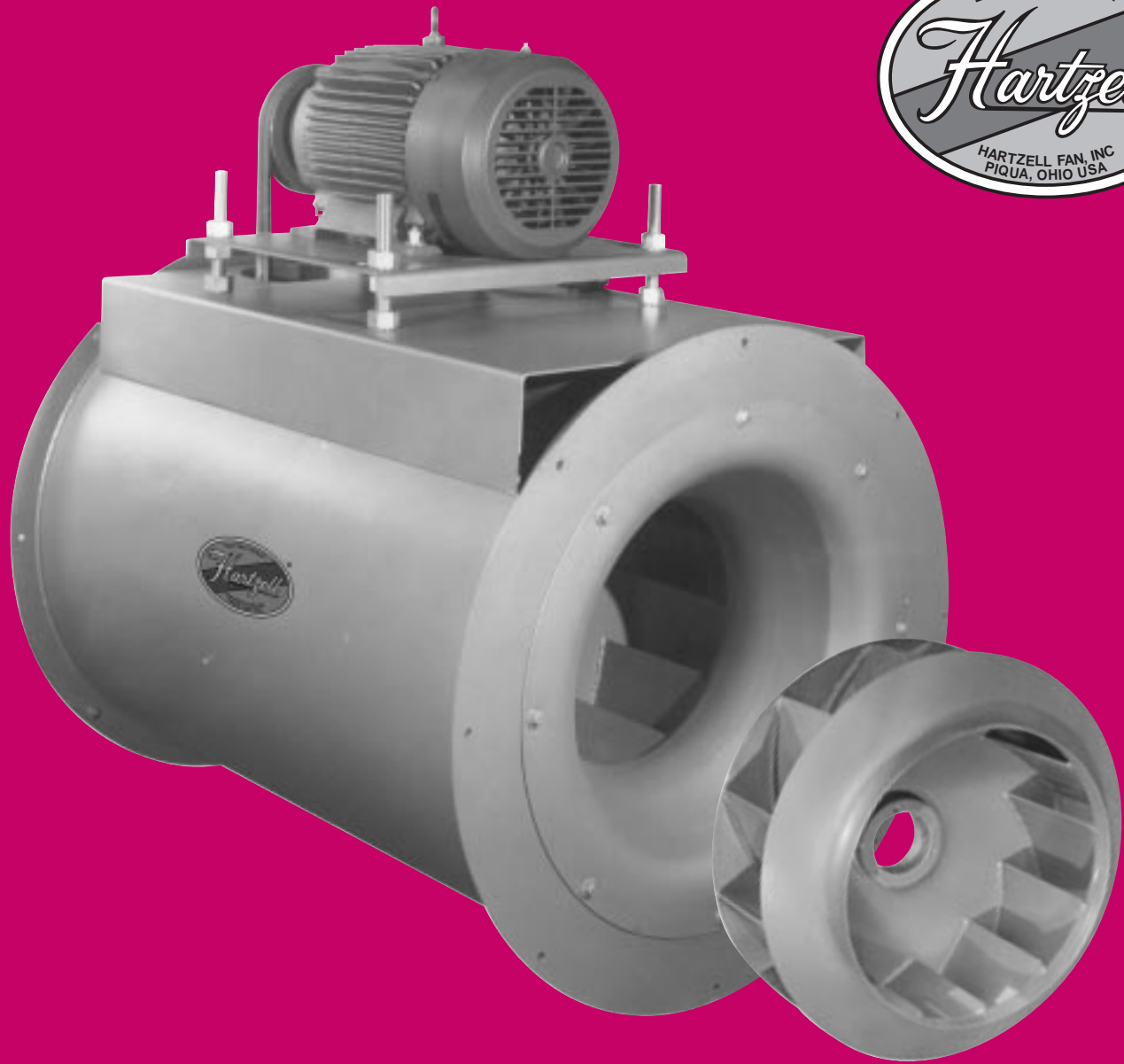

HARTZELL®

Hartzell Fan, Inc., Piqua, Ohio 45356
www.hartzellfan.com

Bulletin A-154-H January 2005

Index

Hartzell Model Code Explanation.....	Page 2	Dimensions and Material Specifications.....	Page 6
General Construction Features.....	Page 3	Rating Tables.....	Pages 7-17
Selection Guide, Temperature Altitude Applications.....	Page 4	Options and Accessories.....	Page 18
Fan Classifications and Mounting Arrangements.....	Page 5	General Construction Options.....	Page 19



Ratings for Air and Sound Performance

Hartzell Fan, Inc. certifies that the Series 04, Steel In-line Centrifugal Fans, Type BA and Type BC, air and sound performance ratings shown herein are reliable and accurate and in accordance with industry standards. The ratings shown are based on tests and procedures performed in accordance with AMCA Standard 210, Standard 300, and Standard 301.

Sound Performance data is available upon request. Please contact the factory and ask for Engineering Publication #SD-154.



Hartzell Fan, Inc. certifies that the Series 04, Steel In-line Centrifugal Fans, Type BA and Type BC, shown herein, is authorized to bear CE Marking in accordance with Machinery Safety Directive 98/37/EC of the European Union. Reference Technical File E.S. 13.2.1.

Hartzell Model Code Explanation

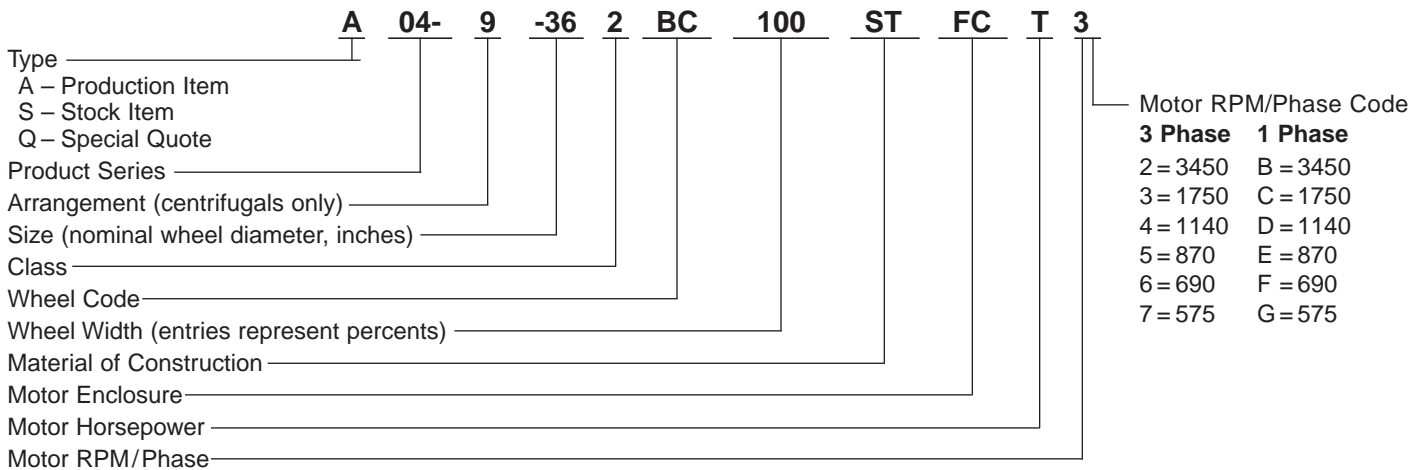

Motor Horsepower

Horsepower	1/4	1/3	1/2	3/4	1	1 1/2	2	3	5	7 1/2	10	15	20	25	30	40	50	60	75	100	125	150	200
Code Letter	D	E	F	G	H	I	J	K	L	M	N	O	P	Q	R	S	T	U	V	W	X	Y	Z

Example:

Assume a needed performance of 22,500 CFM at 8" SP, standard air. Reading the performance table on page 14 we find a Series 04, Size 36" with a type BC wheel and a fan RPM of 1,387 and brake horsepower (BHP) of 43.2. Required motor horsepower is 50.

The model code can be constructed as follows: Type will be a production item (code A), product series for the Steel In-Line Centrifugal Fan is 04, arrangement required for the application is 9,

size is 36, class of construction is II, (Code "2"), wheel type is BC, material for construction is Steel (code ST), motor enclosure will be Totally Enclosed Fan Cooled (code FC), motor horsepower is 50 (code T), and motor RPM/phase is 1750 (code 3).

Note: All other informational fields must be filled with hyphens/dashes (-) if they are not applicable to the fan being considered.

This bulletin lists Hartzell's line of Steel In-Line Centrifugal Fans and accessories. More than 70 Hartzell offices can provide specific performance and installation data to meet your requirements. Call your Hartzell representative for assistance. Visit our website (www.hartzellfan.com) or call toll-free (1-800 336-3267) for the name of your Hartzell representative.



Series 04 Steel In-line Centrifugal Fan

Hartzell Series 04 Steel In-Line Centrifugal Fan offers non-over-loading, high efficiency, low noise, and economy for clean air applications at medium to high pressures. It combines the design advantages of the axial flow fan with the performance characteristics of the centrifugal fan. The "tubular centrifugal," or in-line fan, offers straight airflow for duct installations with the proven, highly efficient, backward curved airfoil-bladed wheel in a vane-equipped housing. This design saves space as compared to the traditional scroll-type centrifugal housing by incorporating a tubular housing. The design allows the unit to be installed directly in a duct system with the same inlet and discharge dimensions. The inline design incorporates guide vanes and airfoil centrifugal

wheel to produce a compact, highly efficient unit with low noise characteristics.

Applications - Developed for clean air applications where it is advantageous to have the motor out of the airstream with the versatility of a belt drive fan.

Performance - Type BA and BC wheel with inlet cone and housing built in aerodynamically designed straightening vanes produces from **900 CFM to 72,000 CFM** at pressures from **free delivery to 14" W.G.** at **high efficiencies with** non-over-loading horsepower, low noise, and low RPM. Maximum temperature capability is 180°F.



Series 04

Shown with optional equipment.



Hartzell Fan, Inc. certifies that the Series 04, Steel In-line Centrifugal Fans, Type BC and Type BA, air and sound performance ratings shown here-in are reliable and accurate and in

accordance with industry standards. The ratings shown are based on tests and procedures performed in accordance with AMCA Standard 210, Standard 300, and Standard 301.

Sound Performance data is available upon request. Please contact the factory and ask for Engineering Publication #SD-154.

Features

- **Sizes** - 12-49" wheel diameters. Available in Class I, II, and III construction in Arrangements #9 and #1. Also available in Power Roof Ventilator configuration.
- **Standard Construction** - The Hartzell Series 04 Steel In-Line Centrifugal Fans incorporate Heavy Industrial Duty Construction. Designed for heavyweight service with ruggedness, use, long life, reliability, and long life taken together. Housings are continuously welded with platform style motor base built of heavy gauge hot rolled steel.
- **Type BC or BA Wheel** - High efficiency design with tapered inlet side design efficiently moves large volumes of air at high pressures. Wheel has non-overloading horsepower characteristic curve. Split taper bushings are utilized as standard to provide secure attachment to the shaft and easy removal for maintenance.
- **Balancing** - The fan is electronically statically and dynamically balanced to the requirements of Fan Application Category BV-3 of AMCA ANSI Std. 204-96. All fans receive an inspection prior to shipment and, whenever possible, fans are test run.
- **Bearings** - Bearings are heavy duty ball or roller type, in cast iron housings, selected for minimum L-50 Life of 250,000 hours for horizontal fans, and include extended lubrication fittings as standard.
- **Shafts** - Shafts are turned ground and polished, keyed at both ends and sized to operate well below critical speed.
- **Standard Shaft Seal** - A Membrane type neoprene shaft seal is placed where the shaft leaves the housing. Seal is not gas tight.
- **Standard Finish** - Standard fans and accessories are pretreated and painted with blue industrial duty air dry enamel. Alternate coatings are available for corrosive environments.
- **Motor Out of the Airstream** - Exterior mounting on fully adjustable platform style motor base supported by external housing assembly base. Open-end motors are standard. Motors larger than 30 HP will be shipped separately for mounting on unit at job site. Motor HP and frame size limits are identified in Dimensions and Material Specifications table.
- **Drives** - V-Belt Drives are oversized for long life and continuous duty. Variable pitch drives are standard option for 10 HP and below and fixed pitch as standard option above 10 HP. Belts are oil, heat, and static resistant type.
- **Options and Accessories** - See pages 19 and 20.
- **Spark Resistant Construction** - Spark Resistant construction is an available option, see page 19.
- **Special Materials of Construction** - Alternate materials of construction; stainless steel, aluminum, fiberglass housing, and other materials are available upon request.

Wheel Design

Type BC Wheel

The Hartzell backward curved centrifugal Type BC wheels have single thickness airfoil blades. The heavy-duty steel construction is reinforced depending on size and class of construction. The wheel's inlet rim is a tapered spun orifice. The inlet rim is overlapped by the fan's spun inlet cone with closely held tolerances to ensure maximum performance and efficiency.



Type BA Wheel (Airfoil)

The Hartzell backward curved centrifugal Type BA wheels have double thickness hollow airfoil blades. These blades are die formed in a true airfoil shape. The backplate and inlets on the Type BA wheels are the same configuration as the Type BC.



Hartzell Selection Guide

The Hartzell Series 04, Steel In-Line Centrifugal Fan performances on the following pages are based on standard air conditions (sea level, 70°F, and 29.92 inches barometric pressure). Performance data does not include drive losses.

How to use Performance Tables

(1) Select a model for a given air delivery and pressure by looking up the required flow vertically along the left column of the performance table and moving to the required pressure. The model is identified with each table.

(2) Note the required RPM and BHP. Refer to page 2 Hartzell Model Code Explanation for additional details.

(3) If non-standard temperature or altitude is involved, correct to standard air density (see Temperature/Altitude Applications).

When placing your order, be sure to specify the Hartzell Model Code. Be sure to include fan model, performance requirements, operating temperature, motor data (enclosure, voltage, mounting position, etc.), and a list of required accessory items. (See pages 18 and 19.) For selection assistance and additional data contact your local Hartzell Sales Representative for assistance.

Temperature/Altitude Applications

When a fan operates in ambient conditions, generally it is handling standard air at 70°F, 29.92" barometric pressure, weighing 0.075-lbs./cu. ft. For an application where the fan operates at other than ambient conditions (temperature, altitude, or both), correction factors must be applied to the selection of the fan. In addition, the standard construction of the fan must be modified.

Correction factors for temperatures and altitudes are provided in Table 1. When a fan operates at other than ambient conditions,

the correction factors in Table 1 will be required to correct static pressure and horsepower.

Table 2 shows the maximum safe operating speeds for each size fan wheel. At high temperatures, these maximum safe operating speeds should be derated.

Table 3 provides maximum safe speed correction factors by temperature and material construction. An example on the use of these tables appears at the bottom of this page.

Table 1 Altitude/Temperature Correction Factors

Temp.* (°F)	-25	0	25	50	70	100	150	180
Factor	0.82	0.87	0.91	0.96	1.00	1.06	1.15	1.20

Alt.** (Ft.)	0	1,000	2,000	3,000	4,000	5,000	6,000	7,000	8,000	9,000	10,000
Factor	1.00	1.04	1.08	1.12	1.16	1.20	1.25	1.30	1.35	1.40	1.46

Above table has inverted values. Actual density is the reciprocal of the above values. *At sea level. **At 70°F. For corrections involving both temperature and altitude, correction factors should be multiplied.

Example: 150°F at 7000 ft.: Temperature factor 1.15 x altitude factor 1.30 = 1.50 combined correction factor.

Table 2 Maximum Safe Speeds @ 70°F

Size	Maximum Speed (RPM)		
	Class I	Class II	Class III
12	3417	4455	4850
15	2722	3549	4471
18	2147	2800	3527
22	1756	2289	2884
24	1572	2050	2582
27	1401	1827	2302
30	1291	1683	2120
33	1181	1540	1941
36	1083	1412	1779
40	969	1263	1591
44	876	1142	1439
49	796	1037	1307

Use of Correction Factors and Tables

First select size, RPM and BHP of the fan needed.

If temperature or altitude is involved, correct to standard air.

Example: Assume the required performance to be 22,500 CFM at 6" SP, 150°F and 7000 feet altitude.

1. Temperature factor 1.15 x altitude factor 1.30 = 1.50 combined correction factor.
2. Correct SP to standard 6.0" SP x 1.50 = 9.0" SP for 70°F at sea level.
3. A Series 04, size 36" class II Steel In-Line Centrifugal Fan, selected from the rating tables (page 14) for the new condition shows 22,500 CFM at 9.0" SP, 1,455 RPM and 48.8 BHP.
4. Correct the horsepower and static pressure in item 3 to non-standard performance by dividing by factor: 9.0" SP divided by 1.50 = 6.0" SP; 48.8 BHP divided by 1.50 = 32.5 BHP.
5. Check the maximum safe speed. Maximum speed at 70°F for fan size 36" Class III, 1,941 RPM. Using the maximum safe speed factor table for steel construction yields a safe speed factor of 1.00. The maximum safe speed is 1,941 x 1.00 = 1,941 RPM; thus operation at 1,455 RPM at 150°F is satisfactory.
6. Final performance of the unit at the assumed conditions: 22,500 CFM at 6.0" SP, 1,455 RPM, 32.5 BHP at 150°F and 7000 feet altitude.
7. Size motor for cold startups and use a special high altitude motor if altitude exceeds 3300 feet.

Table 3 Maximum Safe Speed Correction Factors*

Material Code	Spark Resistance	Material of Construction Housing/Wheel	Temperature °F.		
			0°F.	70°F.	180°F.
ST	None	Steel / Steel	1.000	1.000	1.000
S4	None	304 Stainless / 304 Stainless	1.000	1.000	1.000
AA	AMCA "A"	Aluminum / Aluminum	0.966	0.948	0.871
AB	AMCA "B"	Steel / Aluminum	0.966	0.948	0.871
AC	AMCA "C"	Steel with Alum Buffer / Steel	1.000	1.000	1.000

*To correct maximum safe operating speeds (Table 2) for high temperatures, multiply those speeds by correction factors from Table 3.



Hartzell Steel In-line Centrifugal Fan Classifications

Hartzell Series 04 Steel In-Line Centrifugal Fans are designed and classified to perform within the centrifugal fan classification parameters established by AMCA Standard No. 2408; AMCA

Publication 99. Hartzell Series 04 Steel In-Line Centrifugal Fans are available in Class I, II and III construction. These parameters are explained in the following table.

Fan Class	Performance Range	Table Shading
I	5" at 1,250 FPM to 2½" at 1,800 FPM	
II	8½" at 1,630 FPM to 4½" at 2,350 FPM	
III	13½" at 2,050 FPM to 6¾" at 2,950 FPM	

* At standard air conditions (70°F., 29.92 in. HG barometric pressure, .075 lbs./ft.3). Static pressure shown in inches of water; outlet velocity shown in feet per minute.

In-line Centrifugal Fan Arrangements

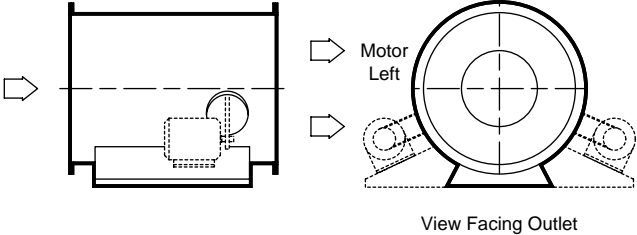
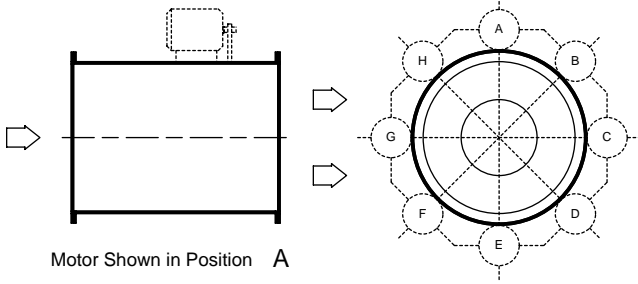
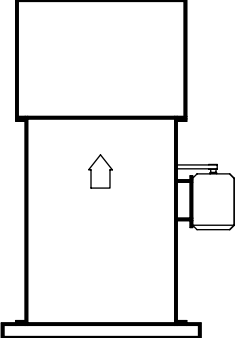
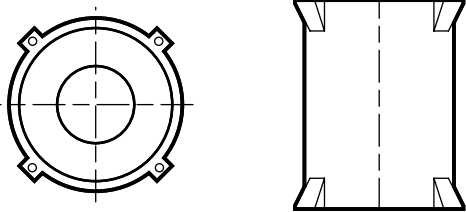
<p>Arrangement 1</p>  <p>View Facing Outlet</p> <p>Motor Left</p> <p>For belt drive. Impeller overhung on a shaft supported by bearing mounted with casing. Motor mounted independent of casing. Horizontal discharge.</p>	<p>Arrangement 9</p>  <p>View Facing Outlet</p> <p>Motor Shown in Position A</p> <p>For belt drive. Impeller overhung on a shaft supported by bearings mounted with casing. Fan may be rotated to achieve motor positions. For horizontal and vertical discharge. Duct mounting shown.</p> <p>Arrangement 9 can be furnished with supports for floor, wall or ceiling mounting. The position of these supports determines which motor locations are available for motor placement. Generally motor locations D, E and F are not available on floor, wall or inverted ceiling mounted fans and motor locations B, C, G & H may not be available for ceiling hung fans.</p>
<p>Arrangement 9 - PRV</p>  <p>When desirable, the in-line centrifugal fan can be mounted as a power roof ventilator for exhaust application. Together with a stack cap and panel, the three elements combine to provide an efficient roof exhauster. Back draft dampers in the stack cap offer weatherproof closure for vertical air discharge.</p>	<p>Vertical Mounting</p>  <p>Another method for mounting vertical fans is shown in the view above. Specify fan to be furnished with ceiling mounting brackets, floor mounting brackets or both.</p> <p>Specify either upblast or downblast discharge for vertically mounted fans.</p>

Adapted from AMCA Standard 99-2404-03, *Drive Arrangements for Centrifugal Fans*, and AMCA Standard 99-2407-03, *Motor Positions for Belt or Chain Drive Centrifugal Fans*, with written permission from Air Movement and Control Association International, Inc.



Dimensions – Series 04, Arrangement 9

Sizes 12" through 49" Classes I, II, and III, Max. Temp 180°F.

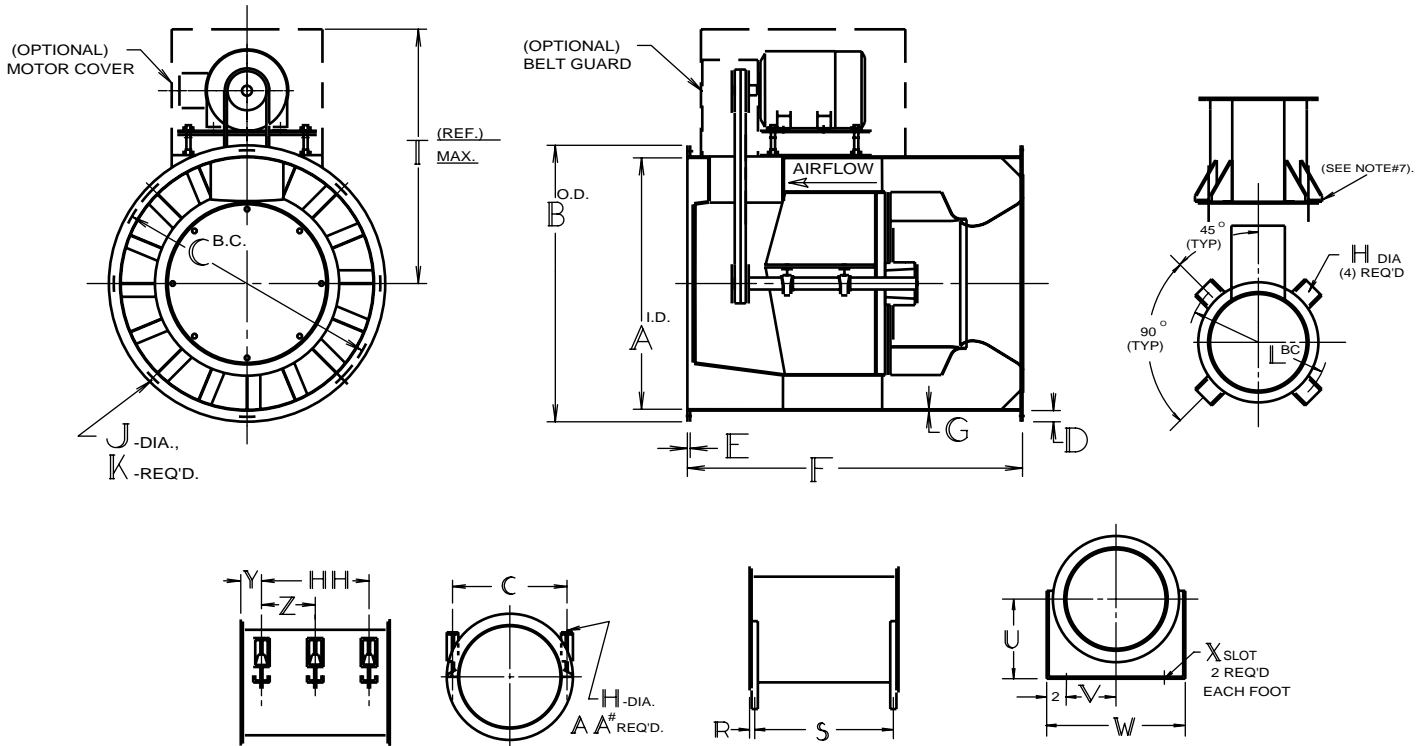

Principal Dimensions (Inches) – Sizes 12" - 29"

Size	A	B	C	E	F	H	J	K	L	S	T	U	W	Max. Motor
12	16 ³ / ₁₆	20 ¹ / ₈	18 ⁷ / ₈	¹ / ₄	26	⁹ / ₁₆ X 1	⁷ / ₁₆ X ³ / ₄	8	23 ¹ / ₈	23	29 ¹ / ₂	13	20 ³ / ₈	215T
15	21 ¹ / ₁₆	24 ³ / ₈	23 ³ / ₈	¹ / ₄	32	⁹ / ₁₆ X 1	⁷ / ₁₆ X ³ / ₄	8	27 ³ / ₈	29	32 ³ / ₄	15	24 ⁵ / ₈	256T
18	25 ³ / ₈	28 ¹¹ / ₁₆	27 ⁷ / ₁₆	¹ / ₄	37	⁹ / ₁₆ X 1	⁷ / ₁₆ X ³ / ₄	8	31 ³ / ₄	34	37 ¹ / ₄	18	28 ⁷ / ₈	286T
22	31	34 ⁵ / ₁₆	33 ¹ / ₁₆	¹ / ₄	43	⁹ / ₁₆ X 1	⁷ / ₁₆ X ³ / ₄	8	37 ¹ / ₂	40	40	20	34 ¹ / ₂	286T
24	33 ³ / ₄	38 ¹ / ₁₆	36 ⁵ / ₁₆	¹ / ₄	46	¹³ / ₁₆ X 1 ¹ / ₈	⁷ / ₁₆ X ³ / ₄	8	42 ¹ / ₁₆	43	41 ³ / ₈	22	38 ¹ / ₂	286T
27	37 ⁷ / ₈	42 ¹ / ₄	40 ¹ / ₂	¹ / ₄	51	¹³ / ₁₆ X 1 ¹ / ₈	⁷ / ₁₆ X ³ / ₄	8	46 ³ / ₁₆	48	46 ³ / ₄	24	42 ³ / ₄	326T
30	41 ¹ / ₈	45 ¹ / ₂	43 ³ / ₄	¹ / ₄	55	¹³ / ₁₆ X 1 ¹ / ₈	⁹ / ₁₆ X 1	8	49 ⁷ / ₁₆	52	51 ¹ / ₂	26	46	365T
33	45 ¹ / ₄	49 ⁵ / ₈	47 ⁷ / ₈	¹ / ₄	60	¹³ / ₁₆ X 1 ¹ / ₈	⁹ / ₁₆ X 1	16	53 ⁵ / ₈	57	53 ¹ / ₂	28	50	365T
36	49 ³ / ₈	53 ¹ / ₄	52	¹ / ₄	65	¹³ / ₁₆ X 1 ¹ / ₈	⁹ / ₁₆ X 1	16	57 ¹ / ₄	62	55 ⁵ / ₈	31	54 ¹ / ₄	365T
40	55 ³ / ₁₆	60 ⁵ / ₈	58 ³ / ₈	³ / ₈	72	¹³ / ₁₆ X 1 ¹ / ₂	⁹ / ₁₆ X 1	16	65 ¹ / ₂	68 ¹ / ₄	61 ³ / ₈	34	51	405T
44	61	66 ³ / ₈	54 ³ / ₁₆	³ / ₈	79	¹³ / ₁₆ X 1 ¹ / ₂	⁹ / ₁₆ X 1	16	71 ⁵ / ₁₆	75 ¹ / ₄	64 ¹ / ₄	37	67	405T
49	67 ³ / ₁₆	72 ⁵ / ₈	70 ³ / ₈	³ / ₈	87	¹³ / ₁₆ X 1 ¹ / ₂	⁹ / ₁₆ X 1	16	77 ¹ / ₂	83 ¹ / ₄	67 ³ / ₈	40	73	405T

Material Specifications/Weight

Size	Outer Housing	Inner Housing	Shaft & Bearings						Max Weight *		
			Class I		Class II		Class III		Arr. 1	Arr. 9	PRV Arr.
			Size	Brg Type	Size	Brg Type	Size	Brg Type			
12	10 GA	12 GA	1 ³ / ₁₆	Ball	1 ⁷ / ₁₆	Ball	1 ⁷ / ₁₆	Roller	154	207	304
15	10 GA	12 GA	1 ³ / ₁₆	Ball	1 ⁷ / ₁₆	Ball	1 ⁷ / ₁₆	Roller	224	298	426
18	10 GA	12 GA	1 ⁷ / ₁₆	Ball	1 ⁷ / ₁₆	Roller	1 ¹¹ / ₁₆	Roller	331	431	583
22	10 GA	10 GA	1 ⁷ / ₁₆	Roller	1 ¹¹ / ₁₆	Roller	1 ¹⁵ / ₁₆	Roller	529	641	831
24	10 GA	10 GA	1 ¹¹ / ₁₆	Roller	1 ¹⁵ / ₁₆	Roller	1 ¹⁵ / ₁₆	Roller	624	738	986
27	10 GA	10 GA	1 ¹¹ / ₁₆	Roller	1 ¹⁵ / ₁₆	Roller	2 ³ / ₁₆	Roller	870	1049	1329
30	10 GA	10 GA	1 ¹⁵ / ₁₆	Roller	1 ¹⁵ / ₁₆	Roller	2 ⁷ / ₁₆	Roller	1030	1202	1508
33	10 GA	10 GA	2 ³ / ₁₆	Roller	2 ³ / ₁₆	Roller	2 ⁷ / ₁₆	Roller	1265	1465	1813
36	10 GA	10 GA	2 ³ / ₁₆	Roller	2 ¹¹ / ₁₆	Roller	2 ¹¹ / ₁₆	Roller	1524	1727	2123
40	7 GA	10 GA	2 ⁷ / ₁₆	Roller	2 ¹⁵ / ₁₆	Roller	2 ¹⁵ / ₁₆	Roller	2074	2300	2839
44	7 GA	10 GA	2 ⁷ / ₁₆	Roller	2 ¹⁵ / ₁₆	Roller	2 ¹⁵ / ₁₆	Roller	2539	2817	3436
49	7 GA	7 GA	2 ¹¹ / ₁₆	Roller	3 ⁷ / ₁₆	Roller	3 ¹¹ / ₁₆	Roller	3374	3661	4330

Max Weight is approximate and based on Class III - steel construction, less motor, drives, and optional equipment.

Dimensions and specifications are subject to change. Certified prints are available.



Rating Tables

Class I Class II Class III

Size 12, Type BC, A04- -12_BC100

Wheel Diameter: 12.25"
Outlet Area: 1.54 Sq. Ft.

CFM	Outlet Velocity FPM	Static Pressure															
		1/2"		1"		1 1/2"		2"		2 1/2"		3"		3 1/2"		4"	
		RPM	BHP	RPM	BHP	RPM	BHP	RPM	BHP	RPM	BHP	RPM	BHP	RPM	BHP	RPM	BHP
900	584	1279	0.13	1545	0.22	1799	0.33	2036	0.44	2256	0.56						
1200	778	1531	0.21	1751	0.33	1951	0.45	2147	0.59	2337	0.73	2520	0.87	2696	1.02	2864	1.18
1500	973	1807	0.32	1995	0.47	2168	0.63	2328	0.77	2488	0.94	2645	1.11	2799	1.28	2949	1.45
1800	1167	2116	0.49	2254	0.65	2412	0.83	2558	1.03	2693	1.20	2826	1.38	2959	1.58	3090	1.80
2100	1362	2423	0.71	2533	0.89	2670	1.09	2803	1.30	2930	1.53	3050	1.75	3165	1.94	3278	2.15
2400	1556	2727	1.00	2842	1.20	2938	1.42	3061	1.65	3178	1.88	3290	2.13	3398	2.40	3502	2.65
2700	1751	3034	1.36	3153	1.58	3233	1.82	3326	2.07	3437	2.33	3541	2.59	3643	2.86	3741	3.16
3000	1946	3346	1.82	3457	2.05	3543	2.31	3613	2.58	3702	2.86	3803	3.14	3897	3.43	3990	3.73
3300	2140	3662	2.37	3761	2.62	3854	2.89	3921	3.18	3986	3.48	4067	3.79	4159	4.10	4247	4.42
3600	2335	3980	3.03	4066	3.29	4159	3.58	4233	3.89	4292	4.21	4352	4.53	4426	4.87	4508	5.21
3900	2529	4298	3.81	4375	4.09	4462	4.39	4542	4.71	4602	5.05	4656	5.39	4712	5.75	4779	6.11
4200	2724	4618	4.71	4688	5.01	4767	5.32	4846	5.66	4914	6.01	4966	6.38	5016	6.75	5067	7.13
4500	2918	4938	5.75	5003	6.06	5073	6.39	5149	6.74	5219	7.11	5278	7.50	5326	7.89	5373	8.29
4800	3113	5259	6.93	5320	7.26	5382	7.61	5454	7.97	5523	8.36	5586	8.76	5638	9.17		
CFM	OV FPM	5"		6"		7"		8"		9"		10"		12"		14"	
		RPM	BHP	RPM	BHP	RPM	BHP	RPM	BHP	RPM	BHP	RPM	BHP	RPM	BHP	RPM	BHP
1400	908	3214	1.71	3496	2.10	3762	2.51										
1600	1038	3270	1.93	3537	2.33	3792	2.76	4035	3.21	4267	3.68						
1800	1167	3348	2.20	3598	2.61	3840	3.04	4072	3.51	4297	4.00	4513	4.50				
2000	1297	3448	2.49	3681	2.94	3907	3.39	4128	3.85	4342	4.36	4550	4.88	4948	5.98	5323	7.15
2200	1427	3567	2.77	3782	3.29	3994	3.78	4202	4.28	4405	4.78	4604	5.30	4986	6.44	5351	7.64
2400	1556	3701	3.09	3901	3.62	4099	4.19	4294	4.74	4486	5.27	4674	5.81	5040	6.95	5392	8.18
2600	1686	3851	3.51	4034	4.00	4219	4.58	4401	5.20	4582	5.79	4760	6.38	5109	7.55	5446	8.78
2800	1816	4007	3.96	4181	4.49	4352	5.02	4523	5.65	4693	6.31	4861	6.96	5192	8.22	5515	9.48
3000	1946	4167	4.38	4337	5.02	4498	5.58	4657	6.16	4817	6.82	4976	7.52	5290	8.91	5597	10.3
3200	2075	4332	4.82	4496	5.54	4652	6.20	4803	6.80	4952	7.40	5102	8.10	5399	9.60		
3400	2205	4499	5.33	4658	6.05	4811	6.81	4957	7.50	5099	8.13	5239	8.76	5521	10.3		
3600	2335	4670	5.90	4824	6.61	4972	7.41	5115	8.21	5253	8.93	5387	9.59	5652	11.0		
3800	2464	4845	6.52	4993	7.26	5137	8.04	5276	8.88	5411	9.73	5541	10.5				
4200	2724	5196	7.92	5340	8.72	5475	9.53	5606	10.4								

Size 15, Type BC, A04- -15_BC100

Wheel Diameter: 15.375"
Outlet Area: 2.42 Sq. Ft.

CFM	Outlet Velocity FPM	Static Pressure															
		1/2"		1"		1 1/2"		2"		2 1/2"		3"		3 1/2"		4"	
		RPM	BHP	RPM	BHP	RPM	BHP	RPM	BHP	RPM	BHP	RPM	BHP	RPM	BHP	RPM	BHP
1000	413	870	0.12	1147	0.24												
1500	620	1052	0.22	1255	0.38	1450	0.55	1633	0.73	1805	0.92	1966	1.14				
2000	826	1268	0.36	1439	0.57	1590	0.76	1740	1.00	1885	1.22	2026	1.45	2162	1.69	2294	1.95
2500	1033	1510	0.57	1648	0.81	1783	1.08	1906	1.32	2026	1.58	2145	1.87	2263	2.16	2378	2.44
3000	1240	1772	0.88	1870	1.15	1992	1.44	2105	1.75	2210	2.07	2311	2.35	2411	2.66	2511	3.01
3500	1446	2029	1.29	2117	1.59	2212	1.91	2316	2.25	2413	2.61	2507	3.00	2596	3.35	2682	3.68
4000	1653	2286	1.82	2379	2.15	2447	2.51	2536	2.89	2627	3.27	2713	3.67	2797	4.11	2878	4.56
4500	1860	2547	2.51	2639	2.86	2705	3.25	2767	3.66	2847	4.08	2929	4.52	3007	4.95	3083	5.42
5000	2066	2812	3.35	2895	3.73	2967	4.15	3021	4.59	3079	5.05	3150	5.52	3226	6.00	3297	6.48
5500	2273	3079	4.38	3151	4.78	3226	5.23	3282	5.70	3330	6.19	3384	6.69	3448	7.21	3517	7.74
6000	2479	3347	5.61	3410	6.04	3482	6.50	3545	7.00	3591	7.53	3635	8.06	3683	8.61	3741	9.17
6500	2686	3616	7.05	3673	7.51	3738	8.00	3801	8.52	3854	9.08	3896	9.65	3937	10.2	3980	10.8
7000	2893	3887	8.73	3939	9.22	3996	9.74	4057	10.3	4113	10.9	4159	11.5	4197	12.1	4235	12.7
7500	3099	4157	10.7	4206	11.2	4256	11.7	4314	12.3	4369	12.9	4419	13.5	4460	14.2	4496	14.8
CFM	OV FPM	5"		6"		7"		8"		9"		10"		12"		14"	
		RPM	BHP	RPM	BHP	RPM	BHP	RPM	BHP	RPM	BHP	RPM	BHP	RPM	BHP	RPM	BHP
2100	868	2550	2.59	2779	3.20												
2400	992	2586	2.90	2804	3.52	3010	4.19	3207	4.89								
2700	1116	2639	3.27	2844	3.90	3041	4.59	3230	5.32	3412	6.07	3586	6.86				
3000	1240	2707	3.70	2899	4.37	3085	5.06	3266	5.80	3441	6.58	3609	7.39	3931	9.10		
3300	1364	2791	4.13	2969	4.89	3144	5.63	3315	6.37	3482	7.16	3644	7.99	3955	9.75	4250	11.6
3600	1488	2886	4.57	3052	5.40	3216	6.24	3377	7.04	3536	7.85	3690	8.67	3990	10.5	4276	12.4
3900	1612	2993	5.11	3147	5.92	3300	6.83	3452	7.74	3601	8.61	3749	9.49	4035	11.3	4311	13.2
4200	1736	3109	5.76	3252	6.54	3395	7.44	3538	8.41	3679	9.40	3818	10.3	4091	12.2	4356	14.2
4500	1860	3229	6.42	3366	7.31	3499	8.14	3633	9.11	3766	10.2	3898	11.2	4158	13.2	4412	15.3
4800	1983	3351	7.06	3485	8.12	3612	9.02	3737	9.91	3862	10.9	3987	12.0	4234	14.3	4477	16.5
5100	2107	3476	7.74	3606	8.87	3730	9.96	3850	10.9	3967	11.9	4085	12.9	4319	15.3		
5400	2231	3604	8.52	3730	9.66	3851	10.9	3967	12.0	4079	13.0	4190	14.0	4413	16.3		
5700	2355	3734	9.38	3856	10.5	3973	11.8	4087	13.0	4197	14.2	4303	15.2	4513	17.5		
6000	2479	3866	10.3	3984	11.5	4098	12.7	4209	14.0	4317	15.4	4420	16.6				

Performance shown is for installation Type D: ducted inlet/ducted outlet. Power rating (BHP) does not include drive losses. Performance data is based on standard air conditions (0.075 #/ft.3). Performance ratings do not include the effects of appurtenances in the airstream. **MOST EFFICIENT FAN SELECTION APPEARS IN BOLD PRINT.** To complete model code, add arrangement, class of construction, material code, motor enclosure code, motor horsepower code and motor speed code. Refer to page 2 for more information.



Rating Tables

Class I

Class II

Class III

Size 18, Type BC, A04- -18_BC100

Wheel Diameter: 18.5"
Outlet Area: 3.51 Sq. Ft.

CFM	Outlet Velocity FPM	Static Pressure															
		1/2"		1"		1 1/2"		2"		2 1/2"		3"		3 1/2"		4"	
		RPM	BHP	RPM	BHP	RPM	BHP	RPM	BHP	RPM	BHP	RPM	BHP	RPM	BHP	RPM	BHP
2100	598	806	0.29	979	0.52												
2800	797	959	0.46	1105	0.75	1236	1.04	1361	1.38								
3500	997	1130	0.74	1253	1.06	1367	1.42	1475	1.78	1577	2.17	1676	2.59	1777	3.03		
4200	1196	1314	1.11	1413	1.48	1515	1.89	1611	2.32	1703	2.75	1791	3.18	1875	3.65	1958	4.15
4900	1395	1502	1.61	1586	2.05	1672	2.46	1761	2.95	1844	3.46	1924	3.97	2002	4.45	2077	4.95
5600	1595	1693	2.26	1768	2.75	1841	3.24	1917	3.71	1995	4.28	2069	4.86	2141	5.44	2210	6.01
6300	1794	1885	3.07	1955	3.60	2019	4.19	2085	4.72	2153	5.25	2222	5.88	2290	6.53	2354	7.19
7000	1993	2080	4.06	2143	4.67	2203	5.29	2261	5.94	2321	6.51	2381	7.09	2443	7.77	2505	8.49
7700	2192	2276	5.24	2334	5.94	2390	6.59	2443	7.30	2495	8.01	2550	8.64	2605	9.27	2661	9.98
8400	2392	2473	6.65	2526	7.44	2578	8.15	2628	8.88	2676	9.67	2725	10.4	2775	11.1	2825	11.8
9100	2591	2670	8.29	2719	9.19	2768	9.97	2815	10.7	2861	11.6	2905	12.4	2950	13.2	2996	14.0
9800	2790	2868	10.2	2914	11.2	2959	12.1	3004	12.9	3047	13.7	3089	14.6	3130	15.5	3172	16.4
10500	2990	3066	12.4	3109	13.4	3152	14.4	3194	15.3	3235	16.2	3275	17.1	3314	18.1	3353	19.1
11200	3189	3265	14.9	3306	16.0	3346	17.1	3385	18.1	3424	19.0	3463	19.9	3500	20.9	3536	22.0
CFM	OV FPM	5"		6"		7"		8"		9"		10"		12"		14"	
		RPM	BHP	RPM	BHP	RPM	BHP	RPM	BHP	RPM	BHP	RPM	BHP	RPM	BHP	RPM	BHP
		4400	1253	2148	5.43												
4800	1367	2205	5.93	2351	7.11	2499	8.34										
5200	1481	2273	6.49	2406	7.71	2541	8.99	2678	10.3								
5600	1595	2345	7.13	2473	8.36	2597	9.68	2722	11.1	2849	12.5						
6000	1708	2420	7.88	2544	9.10	2662	10.4	2778	11.9	2894	13.3	3013	14.8				
6400	1822	2499	8.69	2618	9.96	2733	11.3	2844	12.7	2952	14.2	3061	15.8	3283	19.0		
6800	1936	2581	9.52	2695	10.9	2806	12.3	2914	13.7	3018	15.2	3121	16.8	3326	20.1	3535	23.6
7200	2050	2665	10.4	2775	11.9	2883	13.3	2987	14.8	3089	16.3	3187	17.9	3379	21.3	3576	24.9
7600	2164	2752	11.3	2859	12.9	2962	14.5	3063	16.0	3162	17.5	3258	19.1	3443	22.6	3625	26.3
8000	2278	2839	12.3	2944	14.0	3044	15.6	3141	17.3	3237	18.9	3331	20.5	3511	23.9	3685	27.7
8400	2392	2928	13.4	3031	15.1	3128	16.8	3222	18.6	3315	20.3	3406	22.0	3582	25.4	3751	29.2
8800	2506	3019	14.5	3118	16.3	3214	18.1	3306	19.9	3395	21.8	3483	23.5	3655	27.1		
9200	2620	3113	15.8	3207	17.6	3301	19.5	3391	21.4	3478	23.3	3564	25.2	3731	28.9		
9600	2733	3209	17.3	3298	18.9	3389	20.9	3478	22.9	3563	24.9	3646	26.9				

Size 18, Type BA, A04- -18_BA100

Wheel Diameter: 18.5"
Outlet Area: 3.51 Sq. Ft.

CFM	Outlet Velocity FPM	Static Pressure															
		1/2"		1"		1 1/2"		2"		2 1/2"		3"		3 1/2"		4"	
		RPM	BHP	RPM	BHP	RPM	BHP	RPM	BHP	RPM	BHP	RPM	BHP	RPM	BHP	RPM	BHP
2100	598	819	0.29	1028	0.56	1215	0.90	1383	1.27								
2800	797	962	0.45	1128	0.75	1287	1.11	1436	1.52	1576	1.97	1707	2.44	1831	2.95	1948	3.47
3500	997	1132	0.69	1261	1.03	1394	1.41	1523	1.84	1647	2.31	1766	2.83	1880	3.37	1990	3.95
4200	1196	1310	1.03	1418	1.42	1526	1.84	1637	2.29	1747	2.78	1853	3.31	1956	3.88	2056	4.48
4900	1395	1493	1.49	1589	1.92	1679	2.39	1772	2.88	1868	3.39	1963	3.94	2056	4.53	2147	5.15
5600	1595	1679	2.09	1765	2.56	1847	3.07	1925	3.61	2007	4.17	2090	4.75	2174	5.36	2256	5.99
6300	1794	1868	2.84	1945	3.36	2021	3.91	2092	4.49	2161	5.10	2234	5.73	2308	6.37	2382	7.03
7000	1993	2058	3.77	2129	4.33	2198	4.93	2265	5.55	2328	6.20	2391	6.88	2455	7.57	2521	8.27
7700	2192	2250	4.89	2316	5.50	2378	6.14	2440	6.81	2501	7.50	2558	8.22	2615	8.96	2673	9.72
8400	2392	2442	6.23	2504	6.88	2562	7.57	2619	8.28	2676	9.02	2731	9.78	2784	10.6	2835	11.4
9100	2591	2635	7.80	2693	8.50	2748	9.23	2801	9.99	2853	10.8	2905	11.6	2956	12.4	3005	13.2
9800	2790	2829	9.62	2884	10.4	2935	11.1	2985	11.9	3034	12.8	3083	13.6	3131	14.5	3178	15.4
10500	2990	3023	11.7	3075	12.5	3124	13.3	3171	14.2	3217	15.1	3262	15.9	3308	16.9	3353	17.8
11200	3189	3218	14.1	3267	14.9	3314	15.8	3358	16.7	3402	17.6	3445	18.6	3487	19.5	3530	20.5
CFM	OV FPM	5"		6"		7"		8"		9"		10"		12"		14"	
		RPM	BHP	RPM	BHP	RPM	BHP	RPM	BHP	RPM	BHP	RPM	BHP	RPM	BHP	RPM	BHP
		4400	1253	2267	5.97	2446	7.37	2615	8.86	2777	10.4	2931	12.0	3078	13.7		
4800	1367	2311	6.38	2482	7.82	2646	9.35	2803	11.0	2953	12.6	3098	14.3	3371	17.9		
5200	1481	2361	6.84	2524	8.31	2682	9.88	2834	11.5	2981	13.2	3122	15.0	3390	18.7	3642	22.6
5600	1595	2418	7.37	2574	8.86	2725	10.4	2871	12.1	3013	13.9	3151	15.7	3414	19.6	3661	23.6
6000	1708	2480	7.95	2629	9.46	2774	11.1	2914	12.8	3052	14.6	3185	16.5	3441	20.4	3684	24.5
6400	1822	2546	8.62	2689	10.1	2828	11.8	2963	13.5	3095	15.3	3225	17.2	3474	21.2	3711	25.5
6800	1936	2618	9.35	2754	10.9	2887	12.5	3017	14.3	3145	16.1	3269	18.1	3511	22.1	3743	26.5
7200	2050	2693	10.2	2822	11.7	2951	13.4	3076	15.2	3199	17.0	3319	19.0	3553	23.1		
7600	2164	2772	11.0	2895	12.6	3018	14.3	3139	16.1	3257	18.0	3373	20.0	3599	24.2		
8000	2278	2855	12.0	2972	13.6	3089	15.4	3205	17.2	3319	19.1	3431	21.1	3651	25.3		
8400	2392	2942	13.0	3052	14.7	3164	16.5	3274	18.3	3385	20.2	3494	22.2	3706	26.5		
8800	2506	3031	14.1	3135	15.9	3242	17.7	3348	19.5	3454	21.5	3559	23.5				
9200	2620	3125	15.3	3222	17.1	3323	19.0	3425	20.9	3526	22.8	3627	24.9				
9600	2733	3220	16.6	3311	18.4	3407	20.3	3504	22.3	3602	24.3	3699	26.4				

Performance shown is for installation Type D: ducted inlet/ducted outlet. Power rating (BHP) does not include drive losses. Performance data is based on standard air conditions (0.075 #/ft.3). Performance ratings do not include the effects of appurtenances in the airstream. MOST EFFICIENT FAN SELECTION APPEARS IN BOLD PRINT. To complete model code, add arrangement, class of construction, material code, motor enclosure code, motor horsepower code and motor speed code. Refer to page 2 for more information.



Rating Tables

Class I Class II Class III

Size 22, Type BC, A04- -22_BC100

Wheel Diameter: 22.625"
Outlet Area: 5.24 Sq. Ft.

CFM	Outlet Velocity FPM	Static Pressure															
		1/2"		1"		1 1/2"		2"		2 1/2"		3"		3 1/2"		4"	
		RPM	BHP	RPM	BHP	RPM	BHP	RPM	BHP	RPM	BHP	RPM	BHP	RPM	BHP	RPM	BHP
3000	572	643	0.41	790	0.74												
4000	763	760	0.64	883	1.05	994	1.48	1101	1.98								
5000	954	892	1.00	996	1.48	1093	1.99	1183	2.50	1268	3.09	1354	3.71				
6000	1145	1034	1.50	1119	2.01	1206	2.62	1286	3.24	1363	3.84	1437	4.49	1508	5.19	1579	5.92
7000	1336	1180	2.15	1251	2.78	1326	3.38	1401	4.11	1470	4.83	1538	5.54	1603	6.24	1666	7.00
8000	1526	1328	3.00	1392	3.71	1455	4.40	1521	5.12	1587	5.94	1648	6.77	1708	7.60	1767	8.39
9000	1717	1478	4.07	1536	4.84	1592	5.68	1649	6.41	1707	7.23	1766	8.15	1822	9.09	1876	10.0
10000	1908	1629	5.37	1683	6.23	1734	7.13	1783	8.03	1835	8.85	1888	9.74	1941	10.8	1993	11.8
11000	2099	1782	6.93	1831	7.91	1878	8.85	1924	9.88	1969	10.8	2016	11.7	2064	12.7	2112	13.8
12000	2290	1935	8.77	1981	9.88	2025	10.9	2067	12.0	2108	13.1	2150	14.1	2193	15.1	2237	16.1
13000	2480	2089	10.9	2131	12.2	2172	13.3	2213	14.4	2251	15.6	2289	16.8	2328	17.9	2368	19.0
14000	2671	2243	13.4	2283	14.8	2321	16.0	2359	17.2	2396	18.4	2431	19.7	2467	21.0	2503	22.2
15000	2862	2398	16.3	2435	17.8	2471	19.1	2507	20.4	2542	21.7	2575	23.0	2609	24.4	2642	25.8
16000	3053	2553	19.5	2588	21.1	2622	22.7	2656	24.0	2689	25.4	2721	26.7	2753	28.2	2784	29.7
CFM	OV FPM	5"		6"		7"		8"		9"		10"		12"		14"	
		RPM	BHP	RPM	BHP	RPM	BHP	RPM	BHP	RPM	BHP	RPM	BHP	RPM	BHP	RPM	BHP
		6600	1259	1758	8.15	1890	9.84										
7200	1374	1805	8.90	1924	10.7	2044	12.5										
7800	1488	1860	9.74	1970	11.6	2080	13.5	2191	15.5								
8400	1603	1920	10.7	2024	12.5	2125	14.5	2227	16.6	2331	18.7						
9000	1717	1981	11.8	2083	13.7	2180	15.7	2274	17.8	2369	20.0	2465	22.2				
9600	1832	2046	13.1	2143	15.0	2237	16.9	2328	19.1	2416	21.3	2505	23.7	2686	28.5		
10200	1946	2114	14.3	2207	16.4	2298	18.4	2386	20.5	2471	22.8	2554	25.2	2722	30.2	2892	35.4
10800	2061	2183	15.6	2273	17.9	2360	20.0	2446	22.2	2529	24.4	2609	26.9	2766	32.0	2926	37.3
11400	2175	2254	17.0	2341	19.4	2425	21.7	2508	24.0	2588	26.3	2667	28.7	2818	33.9	2967	39.4
12000	2290	2326	18.5	2411	21.0	2493	23.5	2572	25.9	2650	28.3	2727	30.7	2874	35.9	3016	41.5
12600	2404	2399	20.1	2483	22.7	2562	25.3	2639	27.9	2714	30.5	2789	33.0	2932	38.1		
13200	2519	2474	21.8	2554	24.5	2633	27.2	2708	30.0	2781	32.7	2852	35.4	2993	40.6		
13800	2633	2550	23.8	2627	26.4	2704	29.2	2778	32.1	2849	35.0	2918	37.9	3055	43.4		
14400	2748	2629	26.0	2702	28.5	2776	31.4	2849	34.4	2918	37.3	2986	40.3				

Size 22, Type BA, A04- -22_BA100

Wheel Diameter: 22.625"
Outlet Area: 5.24 Sq. Ft.

CFM	Outlet Velocity FPM	Static Pressure															
		1/2"		1"		1 1/2"		2"		2 1/2"		3"		3 1/2"		4"	
		RPM	BHP	RPM	BHP	RPM	BHP	RPM	BHP	RPM	BHP	RPM	BHP	RPM	BHP	RPM	BHP
3000	572	656	0.40	832	0.81	988	1.30	1127	1.85								
4000	763	764	0.62	906	1.06	1039	1.59	1164	2.20	1281	2.86	1389	3.56	1492	4.29		
5000	954	894	0.94	1005	1.44	1118	1.99	1227	2.63	1331	3.33	1431	4.09	1526	4.90	1618	5.74
6000	1145	1031	1.39	1123	1.95	1217	2.56	1312	3.22	1404	3.95	1494	4.74	1580	5.58	1664	6.48
7000	1336	1173	2.00	1255	2.62	1332	3.29	1413	4.00	1494	4.76	1575	5.57	1654	6.44	1730	7.37
8000	1526	1318	2.78	1391	3.46	1460	4.20	1528	4.98	1599	5.79	1670	6.64	1741	7.54	1811	8.48
9000	1717	1465	3.76	1531	4.51	1595	5.31	1655	6.16	1715	7.04	1778	7.94	1841	8.88	1905	9.86
10000	1908	1613	4.98	1673	5.79	1732	6.65	1788	7.56	1842	8.51	1896	9.48	1952	10.5	2009	11.5
11000	2099	1762	6.45	1818	7.32	1872	8.25	1924	9.21	1975	10.2	2024	11.3	2072	12.3	2123	13.4
12000	2290	1912	8.19	1965	9.14	2014	10.1	2063	11.2	2111	12.2	2157	13.3	2201	14.5	2246	15.6
13000	2480	2063	10.2	2112	11.3	2158	12.3	2203	13.4	2248	14.5	2292	15.7	2335	16.9	2376	18.1
14000	2671	2214	12.6	2260	13.7	2304	14.8	2346	16.0	2388	17.2	2429	18.4	2470	19.7	2510	20.9
15000	2862	2365	15.4	2409	16.5	2451	17.7	2490	18.9	2529	20.2	2569	21.5	2607	22.8	2645	24.1
16000	3053	2517	18.5	2558	19.7	2598	20.9	2636	22.2	2673	23.6	2709	24.9	2746	26.3	2782	27.7
CFM	OV FPM	5"		6"		7"		8"		9"		10"		12"		14"	
		RPM	BHP	RPM	BHP	RPM	BHP	RPM	BHP	RPM	BHP	RPM	BHP	RPM	BHP	RPM	BHP
		6600	1259	1855	8.94	2001	11.1	2139	13.3	2271	15.6	2397	18.0	2518	20.5		
7200	1374	1891	9.56	2030	11.7	2164	14.0	2292	16.4	2415	18.9	2534	21.5	2757	26.8		
7800	1488	1932	10.3	2066	12.5	2194	14.8	2318	17.3	2438	19.8	2554	22.5	2773	28.1	2979	33.9
8400	1603	1979	11.1	2106	13.3	2229	15.7	2349	18.2	2465	20.8	2578	23.6	2792	29.3	2994	35.3
9000	1717	2030	11.9	2152	14.2	2270	16.6	2385	19.2	2497	21.9	2606	24.7	2815	30.5	3013	36.7
9600	1832	2085	12.9	2201	15.2	2315	17.7	2425	20.3	2533	23.0	2638	25.8	2842	31.8	3036	38.2
10200	1946	2143	14.0	2254	16.4	2363	18.8	2470	21.5	2573	24.2	2675	27.1	2872	33.2	3062	39.7
10800	2061	2205	15.3	2311	17.6	2415	20.1	2518	22.8	2618	25.6	2716	28.5	2907	34.6		
11400	2175	2271	16.6	2371	19.0	2471	21.5	2569	24.2	2666	27.0	2761	30.0	2945	36.2		
12000	2290	2339	18.0	2434	20.5	2529	23.1	2624	25.8	2717	28.6	2809	31.6	2988	37.9		
12600	2404	2410	19.6	2500	22.1	2591	24.7	2681	27.5	2771	30.4	2860	33.4	3033	39.7		
13200	2519	2483	21.2	2568	23.8	2655	26.5	2741	29.4	2828	32.3	2913	35.3				
13800	2633	2560	23.0	2639	25.7	2721	28.5	2804	31.3	2887	34.3	2970	37.4				
14400	2748	2639	24.9	2713	27.7	2791	30.5	2870	33.5	2949	36.5	3029	39.6				

Performance shown is for installation Type D: ducted inlet/ducted outlet. Power rating (BHP) does not include drive losses. Performance data is based on standard air conditions (0.075 #/ft.3). Performance ratings do not include the effects of appurtenances in the airstream. **MOST EFFICIENT FAN SELECTION APPEARS IN BOLD PRINT.** To complete model code, add arrangement, class of construction, material code, motor enclosure code, motor horsepower code and motor speed code. Refer to page 2 for more information.



Rating Tables

Size 24, Type BC, A04- -24_BC100

Wheel Diameter: 24.625"
Outlet Area: 6.21 Sq. Ft.

CFM	Outlet Velocity FPM	Static Pressure															
		1/2"		1"		1 1/2"		2"		2 1/2"		3"		3 1/2"		4"	
		RPM	BHP	RPM	BHP	RPM	BHP	RPM	BHP	RPM	BHP	RPM	BHP	RPM	BHP	RPM	BHP
3600	579	574	0.46	709	0.84	842	1.30	969	1.84	1078	2.41						
4800	773	688	0.76	789	1.20	890	1.69	990	2.24	1090	2.86	1188	3.55	1282	4.29	1366	5.03
6000	966	802	1.17	885	1.66	976	2.26	1057	2.87	1137	3.51	1217	4.19	1298	4.93	1377	5.74
7200	1159	936	1.81	1016	2.44	1070	2.94	1149	3.69	1218	4.40	1285	5.14	1351	5.91	1418	6.71
8400	1352	1069	2.65	1125	3.23	1201	4.06	1244	4.60	1313	5.49	1374	6.31	1432	7.15	1489	8.02
9600	1545	1204	3.72	1259	4.44	1312	5.18	1376	6.11	1411	6.70	1467	7.62	1526	8.63	1579	9.57
10800	1738	1341	5.07	1392	5.91	1435	6.64	1492	7.65	1546	8.66	1576	9.29	1617	10.2	1674	11.4
12000	1931	1480	6.75	1525	7.67	1569	8.58	1604	9.34	1662	10.6	1712	11.8	1740	12.5	1771	13.3
13200	2125	1620	8.79	1660	9.78	1701	10.8	1738	11.7	1770	12.6	1825	14.0	1875	15.4	1902	16.2
14400	2318	1761	11.2	1796	12.3	1835	13.4	1872	14.5	1903	15.4	1933	16.4	1983	17.9	2033	19.6
15600	2511	1902	14.1	1934	15.2	1969	16.4	2004	17.6	2037	18.8	2065	19.8	2092	20.8	2136	22.4
16800	2704	2044	17.4	2073	18.6	2104	19.8	2138	21.2	2170	22.5	2200	23.7	2225	24.7	2250	25.8
18000	2897	2187	21.3	2212	22.4	2241	23.8	2272	25.2	2303	26.6	2333	28.0	2359	29.3	2383	30.4
19200	3090	2329	25.6	2353	26.9	2379	28.3	2407	29.7	2436	31.3	2465	32.8	2493	34.2	2518	35.5
CFM	OV FPM	5"		6"		7"		8"		9"		10"		12"		14"	
		RPM	BHP	RPM	BHP	RPM	BHP	RPM	BHP	RPM	BHP	RPM	BHP	RPM	BHP	RPM	BHP
		6300	1014	1534	7.71	1679	9.64	1807	11.6	1928	13.6	2042	15.7				
7200	1159	1552	8.45	1684	10.4	1814	12.5	1937	14.8	2050	17.0	2156	19.3				
8100	1304	1588	9.43	1707	11.4	1825	13.5	1942	15.8	2057	18.2	2167	20.7	2364	25.7	2548	31.0
9000	1449	1639	10.6	1746	12.6	1853	14.7	1960	16.9	2066	19.4	2171	21.9	2375	27.4	2556	33.0
9900	1593	1701	12.0	1798	14.1	1895	16.2	1992	18.4	2090	20.8	2187	23.4	2378	28.9	2565	34.9
10800	1738	1770	13.5	1861	15.7	1949	17.9	2038	20.2	2127	22.6	2216	25.1	2394	30.7	2570	36.7
11700	1883	1842	15.2	1929	17.5	2012	19.8	2094	22.3	2176	24.7	2258	27.3	2422	32.7	2587	38.7
12600	2028	1908	16.8	2000	19.4	2081	21.9	2158	24.4	2234	27.1	2310	29.7	2462	35.2	2615	41.1
13500	2173	1988	18.8	2069	21.4	2152	24.2	2227	26.8	2299	29.6	2370	32.3	2512	38.1	2654	44.0
14400	2318	2086	21.5	2140	23.5	2223	26.6	2298	29.5	2368	32.3	2436	35.2	2569	41.1	2702	47.3
15300	2463	2189	24.6	2231	26.4	2289	28.8	2370	32.3	2439	35.3	2505	38.3	2633	44.4	2758	50.8
16200	2607	2283	27.6	2334	29.9	2375	31.9	2434	34.7	2512	38.4	2577	41.6	2701	47.9		
17100	2752	2361	30.3	2436	33.8	2475	35.8	2517	38.1	2575	41.1	2649	45.1	2771	51.8		
18000	2897	2437	33.0	2524	37.3	2578	40.2	2614	42.3	2656	44.8	2713	48.1				

Size 24, Type BA, A04- -24_BA100

Wheel Diameter: 24.625"
Outlet Area: 6.21 Sq. Ft.

CFM	Outlet Velocity FPM	Static Pressure															
		1/2"		1"		1 1/2"		2"		2 1/2"		3"		3 1/2"		4"	
		RPM	BHP	RPM	BHP	RPM	BHP	RPM	BHP	RPM	BHP	RPM	BHP	RPM	BHP	RPM	BHP
3600	579	580	0.43	742	0.84	894	1.32	1026	1.86								
4800	773	683	0.68	800	1.12	922	1.65	1042	2.26	1156	2.91	1260	3.60	1357	4.32		
6000	966	802	1.05	893	1.54	988	2.10	1085	2.75	1183	3.46	1279	4.21	1372	5.01	1461	5.83
7200	1159	929	1.58	1005	2.13	1081	2.74	1160	3.40	1240	4.15	1322	4.95	1403	5.80	1484	6.69
8400	1352	1059	2.29	1126	2.91	1190	3.58	1256	4.29	1324	5.05	1392	5.88	1460	6.77	1530	7.70
9600	1545	1192	3.19	1252	3.91	1309	4.64	1365	5.41	1423	6.22	1481	7.06	1541	7.97	1600	8.93
10800	1738	1327	4.32	1381	5.14	1432	5.94	1482	6.77	1533	7.65	1583	8.56	1635	9.49	1688	10.5
12000	1931	1463	5.72	1512	6.63	1559	7.52	1605	8.42	1650	9.35	1695	10.3	1741	11.3	1787	12.3
13200	2125	1600	7.42	1644	8.40	1688	9.40	1730	10.4	1772	11.4	1813	12.4	1854	13.5	1895	14.5
14400	2318	1737	9.44	1778	10.5	1819	11.6	1858	12.7	1897	13.7	1935	14.8	1972	15.9	2010	17.1
15600	2511	1876	11.8	1914	12.9	1951	14.1	1988	15.3	2024	16.5	2060	17.6	2095	18.8	2129	20.0
16800	2704	2014	14.6	2050	15.8	2084	17.0	2119	18.3	2153	19.6	2186	20.8	2219	22.0	2252	23.3
18000	2897	2153	17.7	2186	19.0	2219	20.3	2251	21.7	2283	23.1	2315	24.4	2346	25.7	2377	27.1
19200	3090	2292	21.3	2323	22.7	2354	24.1	2385	25.5	2415	27.0	2445	28.4	2474	29.9	2503	31.3
CFM	OV FPM	5"		6"		7"		8"		9"		10"		12"		14"	
		RPM	BHP	RPM	BHP	RPM	BHP	RPM	BHP	RPM	BHP	RPM	BHP	RPM	BHP	RPM	BHP
		6300	1014	1628	7.82	1777	9.71										
7200	1159	1640	8.57	1787	10.6	1924	12.7	2052	14.9								
8100	1304	1661	9.39	1801	11.5	1935	13.7	2061	16.0	2180	18.4	2294	20.8				
9000	1449	1693	10.3	1823	12.5	1950	14.8	2073	17.2	2191	19.7	2303	22.3	2514	27.6		
9900	1593	1737	11.4	1856	13.6	1975	16.0	2091	18.5	2205	21.1	2315	23.8	2524	29.4	2718	35.2
10800	1738	1794	12.6	1901	14.9	2010	17.3	2118	19.9	2226	22.6	2332	25.3	2536	31.1	2727	37.2
11700	1883	1858	14.0	1956	16.3	2055	18.8	2155	21.5	2256	24.2	2356	27.1	2551	33.0	2739	39.3
12600	2028	1929	15.6	2019	17.9	2110	20.5	2202	23.2	2295	26.0	2389	28.9	2574	35.1	2755	41.5
13500	2173	2005	17.4	2089	19.8	2173	22.4	2258	25.1	2344	28.0	2430	31.0	2605	37.2	2777	43.9
14400	2318	2086	19.5	2163	21.9	2241	24.5	2321	27.2	2400	30.1	2481	33.2	2643	39.6	2806	46.4
15300	2463	2170	21.7	2242	24.3	2315	26.9	2389	29.7	2463	32.6	2538	35.7	2690	42.2		
16200	2607	2257	24.2	2324	26.8	2392	29.6	2462	32.4	2532	35.3	2602	38.4	2744	45.0		
17100	2752	2346	26.8	2410	29.6	2473	32.5	2538	35.4	2604	38.3	2670	41.4	2804	48.1		
18000	2897	2437	29.8	2497	32.6	2558	35.6	2619	38.6	2680	41.7	2743	44.8				

Performance shown is for installation Type D: ducted inlet/ducted outlet. Power rating (BHP) does not include drive losses. Performance data is based on standard air conditions (0.075 #/ft.3). Performance ratings do not include the effects of appurtenances in the airstream. MOST EFFICIENT FAN SELECTION APPEARS IN BOLD PRINT. To complete model code, add arrangement, class of construction, material code, motor enclosure code, motor horsepower code and motor speed code. Refer to page 2 for more information.



Rating Tables

Class I Class II Class III

Size 27, Type BC, A04- -27_BC100

Wheel Diameter: 27.625"
Outlet Area: 7.82 Sq. Ft.

CFM	Outlet Velocity FPM	Static Pressure															
		1/2"		1"		1 1/2"		2"		2 1/2"		3"		3 1/2"		4"	
		RPM	BHP	RPM	BHP	RPM	BHP	RPM	BHP	RPM	BHP	RPM	BHP	RPM	BHP	RPM	BHP
4500	575	510	0.57	631	1.05	750	1.63	863	2.31	961	3.02						
6000	767	610	0.95	701	1.49	791	2.11	881	2.80	971	3.58	1059	4.45	1142	5.38	1218	6.30
7500	959	711	1.45	786	2.06	867	2.82	940	3.58	1012	4.38	1083	5.23	1156	6.18	1227	7.19
9000	1150	829	2.24	902	3.04	950	3.66	1021	4.59	1082	5.48	1142	6.42	1202	7.38	1262	8.38
10500	1342	947	3.27	997	4.00	1065	5.03	1104	5.73	1166	6.84	1221	7.86	1273	8.91	1324	10.0
12000	1534	1066	4.60	1116	5.50	1165	6.44	1220	7.57	1252	8.33	1303	9.52	1355	10.8	1403	11.9
13500	1725	1188	6.27	1233	7.32	1272	8.23	1325	9.52	1370	10.7	1398	11.5	1436	12.7	1488	14.2
15000	1917	1310	8.34	1351	9.50	1390	10.6	1422	11.6	1475	13.2	1518	14.6	1543	15.4	1571	16.5
16500	2109	1434	10.8	1470	12.1	1508	13.4	1540	14.5	1569	15.6	1620	17.4	1663	19.1	1687	20.1
18000	2301	1559	13.9	1591	15.2	1626	16.6	1659	17.9	1687	19.1	1714	20.3	1760	22.3	1804	24.3
19500	2492	1685	17.4	1713	18.8	1744	20.3	1776	21.8	1806	23.2	1830	24.5	1855	25.7	1897	27.8
21000	2684	1810	21.5	1836	22.9	1864	24.5	1894	26.2	1923	27.8	1949	29.3	1972	30.6	1995	32.0
22500	2876	1936	26.2	1959	27.7	1985	29.4	2013	31.2	2041	32.9	2067	34.6	2091	36.2	2112	37.6
24000	3067	2062	31.6	2084	33.2	2107	34.9	2133	36.8	2159	38.7	2185	40.5	2209	42.4	2231	44.0
CFM	OV FPM	5"		6"		7"		8"		9"		10"		12"		14"	
		RPM	BHP	RPM	BHP	RPM	BHP	RPM	BHP	RPM	BHP	RPM	BHP	RPM	BHP	RPM	BHP
		7200	920	1366	9.20	1490	11.4	1606	13.8								
8400	1074	1372	10.1	1497	12.5	1615	15.1	1721	17.7	1822	20.4	1919	23.2				
9600	1227	1396	11.2	1509	13.6	1620	16.3	1728	19.2	1831	22.1	1926	25.1	2104	31.3		
10800	1380	1438	12.7	1538	15.1	1638	17.7	1738	20.6	1836	23.7	1933	26.9	2112	33.5	2275	40.3
12000	1534	1493	14.4	1583	16.9	1673	19.6	1762	22.4	1853	25.4	1942	28.7	2118	35.6	2285	43.0
13200	1687	1556	16.3	1638	19.0	1720	21.8	1801	24.6	1883	27.6	1965	30.8	2128	37.8	2288	45.3
14400	1840	1623	18.5	1702	21.3	1777	24.2	1851	27.3	1926	30.4	2001	33.5	2151	40.4	2301	47.9
15600	1994	1688	20.7	1768	23.9	1841	26.9	1910	30.1	1979	33.4	2048	36.7	2186	43.6	2325	51.0
16800	2147	1759	23.1	1835	26.6	1907	30.0	1974	33.3	2039	36.7	2103	40.1	2231	47.3	2360	54.7
18000	2301	1850	26.6	1900	29.2	1976	33.2	2041	36.7	2104	40.2	2165	43.9	2284	51.3	2404	59.0
19200	2454	1947	30.7	1985	33.0	2037	36.1	2110	40.5	2171	44.2	2230	47.9	2344	55.7	2456	63.7
20400	2607	2036	34.8	2081	37.7	2118	40.2	2171	43.7	2240	48.4	2298	52.4	2408	60.4		
21600	2761	2109	38.3	2177	42.9	2213	45.5	2249	48.2	2300	52.0	2365	57.0	2475	65.5		
22800	2914	2182	42.0	2259	47.5	2310	51.3	2342	54.0	2378	57.0	2426	61.1				

Size 27, Type BA, A04- -27_BA100

Wheel Diameter: 27.625"
Outlet Area: 7.82 Sq. Ft.

CFM	Outlet Velocity FPM	Static Pressure															
		1/2"		1"		1 1/2"		2"		2 1/2"		3"		3 1/2"		4"	
		RPM	BHP	RPM	BHP	RPM	BHP	RPM	BHP	RPM	BHP	RPM	BHP	RPM	BHP	RPM	BHP
4500	575	516	0.53	661	1.05	796	1.66	914	2.33								
6000	767	606	0.84	711	1.39	821	2.07	928	2.82	1030	3.64	1123	4.51	1210	5.41		
7500	959	711	1.31	793	1.92	878	2.63	965	3.44	1053	4.32	1139	5.27	1222	6.27	1302	7.31
9000	1150	824	1.96	892	2.65	960	3.41	1031	4.25	1103	5.18	1176	6.19	1249	7.25	1322	8.37
10500	1342	939	2.83	998	3.62	1056	4.45	1115	5.34	1176	6.29	1237	7.33	1299	8.45	1362	9.63
12000	1534	1056	3.95	1110	4.84	1161	5.76	1211	6.73	1263	7.74	1316	8.80	1369	9.93	1423	11.1
13500	1725	1176	5.35	1224	6.37	1270	7.37	1315	8.41	1360	9.51	1406	10.6	1452	11.8	1499	13.0
15000	1917	1296	7.07	1340	8.21	1382	9.32	1423	10.4	1463	11.6	1504	12.8	1545	14.1	1587	15.4
16500	2109	1417	9.17	1457	10.4	1496	11.6	1534	12.9	1571	14.1	1608	15.4	1645	16.7	1682	18.1
18000	2301	1539	11.7	1576	13.0	1612	14.4	1647	15.7	1682	17.0	1716	18.4	1749	19.8	1783	21.2
19500	2492	1661	14.6	1695	16.0	1729	17.5	1762	18.9	1794	20.4	1826	21.8	1857	23.3	1888	24.8
21000	2684	1784	18.0	1815	19.5	1847	21.0	1878	22.7	1908	24.2	1938	25.8	1968	27.3	1997	28.9
22500	2876	1907	21.9	1936	23.5	1966	25.1	1995	26.8	2024	28.6	2052	30.2	2080	31.9	2107	33.6
24000	3067	2030	26.3	2058	28.0	2085	29.8	2113	31.6	2140	33.4	2167	35.2	2193	37.0	2219	38.8
CFM	OV FPM	5"		6"		7"		8"		9"		10"		12"		14"	
		RPM	BHP	RPM	BHP	RPM	BHP	RPM	BHP	RPM	BHP	RPM	BHP	RPM	BHP	RPM	BHP
		7200	920	1446	9.27												
8400	1074	1455	10.2	1588	12.7	1710	15.2										
9600	1227	1469	11.3	1598	13.8	1719	16.6	1832	19.4	1940	22.3						
10800	1380	1494	12.4	1614	15.1	1731	18.0	1843	20.9	1948	24.0	2049	27.2	2238	33.8		
12000	1534	1531	13.8	1641	16.5	1750	19.5	1857	22.6	1960	25.8	2059	29.1	2246	36.1	2419	43.3
13200	1687	1581	15.3	1679	18.2	1780	21.2	1879	24.4	1977	27.7	2073	31.2	2257	38.4	2428	46.0
14400	1840	1639	17.1	1729	20.0	1819	23.1	1911	26.4	2002	29.8	2093	33.4	2270	40.9	2439	48.7
15600	1994	1705	19.1	1787	22.1	1869	25.3	1953	28.7	2037	32.2	2122	35.8	2289	43.5	2452	51.6
16800	2147	1776	21.5	1851	24.5	1927	27.7	2004	31.2	2081	34.8	2160	38.5	2317	46.4	2472	54.7
18000	2301	1851	24.2	1921	27.3	1991	30.5	2062	34.0	2134	37.6	2206	41.5	2352	49.5	2498	58.0
19200	2454	1931	27.2	1995	30.4	2060	33.7	2126	37.2	2193	40.8	2260	44.7	2395	52.9		
20400	2607	2013	30.4	2073	33.8	2133	37.2	2195	40.8	2257	44.5	2320	48.3	2446	56.7		
21600	2761	2097	34.0	2153	37.5	2210	41.1	2268	44.8	2326	48.5	2385	52.4	2503	60.8		
22800	2914	2183	38.0	2236	41.6	2290	45.3	2344	49.1	2398	53.0	2454	57.0				

Performance shown is for installation Type D: ducted inlet/ducted outlet. Power rating (BHP) does not include drive losses. Performance data is based on standard air conditions (0.075 #/ft.3). Performance ratings do not include the effects of appurtenances in the airstream. MOST EFFICIENT FAN SELECTION APPEARS IN BOLD PRINT. To complete model code, add arrangement, class of construction, material code, motor enclosure code, motor horsepower code and motor speed code. Refer to page 2 for more information.



Rating Tables

Class I

Class II

Class III

Size 30, Type BC, A04- -30_BC100

Wheel Diameter: 30.00"
Outlet Area: 9.22 Sq. Ft.

CFM	Outlet Velocity FPM	Static Pressure															
		1/2"		1"		1 1/2"		2"		2 1/2"		3"		3 1/2"		4"	
		RPM	BHP	RPM	BHP	RPM	BHP	RPM	BHP	RPM	BHP	RPM	BHP	RPM	BHP	RPM	BHP
4000	434	418	0.47	563	1.00	685	1.63										
6000	650	499	0.80	603	1.42	700	2.10	797	2.92	889	3.84	970	4.77	1046	5.74		
8000	867	612	1.41	687	2.11	763	2.90	836	3.75	909	4.66	982	5.68	1055	6.79	1125	7.99
10000	1084	726	2.29	794	3.15	848	3.97	913	4.97	972	5.99	1030	7.05	1089	8.15	1147	9.32
12000	1301	849	3.57	897	4.42	956	5.53	998	6.42	1057	7.70	1108	8.87	1157	10.1	1205	11.4
14000	1518	972	5.27	1018	6.32	1066	7.47	1113	8.72	1145	9.63	1195	11.1	1241	12.5	1285	13.9
16000	1735	1099	7.49	1141	8.74	1176	9.82	1223	11.3	1267	12.8	1292	13.7	1326	15.0	1373	16.9
18000	1951	1227	10.3	1263	11.7	1299	13.1	1328	14.2	1373	16.0	1417	17.8	1440	18.9	1464	20.1
20000	2168	1356	13.8	1388	15.3	1422	16.9	1452	18.3	1478	19.6	1516	21.5	1561	23.8	1587	25.2
22000	2385	1486	18.1	1514	19.6	1545	21.4	1575	23.1	1601	24.6	1624	26.0	1656	27.9	1701	30.6
24000	2602	1617	23.2	1641	24.8	1669	26.7	1697	28.6	1724	30.4	1748	32.0	1769	33.5	1795	35.3
26000	2819	1748	29.2	1770	30.9	1794	32.8	1820	34.9	1846	36.9	1871	38.9	1892	40.6	1912	42.3
28000	3036	1879	36.1	1899	38.0	1921	40.0	1945	42.2	1969	44.4	1993	46.6	2016	48.7	2036	50.5
30000	3252	2011	44.2	2029	46.1	2049	48.2	2071	50.5	2093	52.8	2116	55.2	2138	57.5	2159	59.8
CFM	OV FPM	5"		6"		7"		8"		9"		10"		12"		14"	
		RPM	BHP	RPM	BHP	RPM	BHP	RPM	BHP	RPM	BHP	RPM	BHP	RPM	BHP	RPM	BHP
		9000	976	1258	11.2	1375	14.0	1481	16.8	1581	19.8						
10500	1138	1271	12.4	1381	15.3	1489	18.4	1589	21.7	1681	24.9	1769	28.3				
12000	1301	1303	14.0	1400	16.8	1498	20.0	1594	23.4	1688	27.0	1778	30.7	1941	38.1	2091	45.9
13500	1464	1350	16.0	1437	18.9	1524	22.0	1611	25.4	1697	29.0	1783	32.8	1949	41.0	2099	49.3
15000	1626	1409	18.3	1487	21.4	1565	24.6	1643	27.9	1721	31.5	1799	35.3	1954	43.5	2105	52.4
16500	1789	1473	20.9	1547	24.2	1617	27.6	1688	31.1	1759	34.7	1830	38.4	1972	46.5	2114	55.4
18000	1951	1540	23.7	1611	27.3	1678	30.8	1743	34.5	1808	38.3	1873	42.2	2003	50.2	2133	59.1
19500	2114	1603	26.5	1678	30.7	1742	34.5	1805	38.4	1865	42.3	1925	46.4	2045	54.8	2165	63.5
21000	2277	1689	30.6	1739	33.9	1809	38.6	1869	42.6	1928	46.8	1984	51.0	2095	59.8	2207	68.8
22500	2439	1784	35.7	1819	38.4	1870	42.2	1937	47.3	1993	51.6	2048	56.0	2153	65.1	2256	74.6
24000	2602	1871	40.9	1913	44.3	1947	47.2	1996	51.4	2060	56.9	2113	61.6	2215	71.0	2313	80.8
25500	2765	1943	45.3	2006	50.6	2039	53.8	2073	57.0	2119	61.5	2179	67.3	2280	77.4		
27000	2927	2015	50.0	2086	56.4	2134	61.1	2164	64.3	2196	67.8	2239	72.5				
28500	3090	2103	56.4	2154	61.5	2220	68.2	2259	72.6	2286	75.9						

Size 30, Type BA, A04- -30_BA100

Wheel Diameter: 30.00"
Outlet Area: 9.22 Sq. Ft.

CFM	Outlet Velocity FPM	Static Pressure															
		1/2"		1"		1 1/2"		2"		2 1/2"		3"		3 1/2"		4"	
		RPM	BHP	RPM	BHP	RPM	BHP	RPM	BHP	RPM	BHP	RPM	BHP	RPM	BHP	RPM	BHP
4000	434	435	0.46	597	1.01												
6000	650	505	0.75	622	1.38	739	2.13	846	2.96	942	3.86						
8000	867	608	1.25	692	1.93	780	2.76	869	3.69	957	4.70	1041	5.77	1119	6.90	1193	8.08
10000	1084	722	2.02	788	2.80	856	3.67	926	4.64	997	5.73	1069	6.90	1139	8.13	1209	9.42
12000	1301	841	3.09	898	3.99	953	4.96	1009	5.99	1067	7.10	1125	8.33	1184	9.64	1244	11.0
14000	1518	963	4.53	1013	5.58	1060	6.64	1108	7.78	1156	8.97	1205	10.2	1255	11.5	1305	13.0
16000	1735	1087	6.39	1131	7.60	1174	8.79	1215	10.0	1256	11.3	1298	12.7	1341	14.0	1384	15.5
18000	1951	1213	8.74	1252	10.1	1291	11.4	1328	12.8	1365	14.2	1401	15.6	1438	17.1	1476	18.6
20000	2168	1339	11.7	1375	13.1	1410	14.7	1444	16.1	1478	17.6	1511	19.2	1544	20.8	1577	22.4
22000	2385	1466	15.2	1499	16.8	1531	18.5	1563	20.1	1594	21.7	1624	23.4	1654	25.1	1684	26.8
24000	2602	1594	19.4	1624	21.1	1653	22.9	1683	24.8	1712	26.5	1740	28.3	1768	30.1	1795	31.9
26000	2819	1722	24.4	1749	26.2	1777	28.1	1804	30.1	1831	32.1	1858	34.0	1884	35.9	1910	37.9
28000	3036	1850	30.1	1876	32.1	1901	34.1	1927	36.2	1952	38.4	1977	40.5	2002	42.5	2026	44.6
30000	3252	1978	36.7	2002	38.8	2027	41.0	2050	43.2	2074	45.5	2098	47.8	2121	50.0	2144	52.2
CFM	OV FPM	5"		6"		7"		8"		9"		10"		12"		14"	
		RPM	BHP	RPM	BHP	RPM	BHP	RPM	BHP	RPM	BHP	RPM	BHP	RPM	BHP	RPM	BHP
		9000	976	1334	11.3	1457	14.1										
10500	1138	1345	12.6	1466	15.5	1578	18.6	1683	21.8								
12000	1301	1363	13.9	1478	17.0	1588	20.3	1691	23.7	1790	27.3	1883	30.9				
13500	1464	1393	15.5	1499	18.7	1602	22.1	1703	25.7	1800	29.4	1892	33.3	2065	41.3		
15000	1626	1436	17.3	1531	20.6	1627	24.2	1721	27.9	1813	31.8	1903	35.8	2074	44.2	2232	53.0
16500	1789	1490	19.4	1575	22.8	1662	26.5	1749	30.3	1835	34.3	1920	38.5	2085	47.2	2242	56.3
18000	1951	1552	21.8	1630	25.3	1708	29.1	1786	33.0	1866	37.1	1946	41.4	2102	50.4	2254	59.9
19500	2114	1620	24.7	1691	28.2	1762	32.0	1834	36.1	1907	40.3	1980	44.7	2127	53.9	2272	63.7
21000	2277	1693	28.0	1758	31.6	1824	35.4	1890	39.5	1957	43.8	2024	48.3	2160	57.8	2296	67.8
22500	2439	1770	31.7	1830	35.5	1890	39.4	1952	43.4	2014	47.8	2076	52.3	2201	62.0		
24000	2602	1850	35.7	1905	39.7	1962	43.7	2019	47.9	2076	52.2	2134	56.8	2251	66.6		
25500	2765	1932	40.2	1984	44.3	2036	48.6	2089	52.9	2143	57.3	2197	61.9	2306	71.8		
27000	2927	2017	45.2	2065	49.4	2114	53.8	2164	58.3	2214	62.9	2264	67.6				
28500	3090	2102	50.7	2148	55.1	2195	59.6	2241	64.3	2288	69.0						

Performance shown is for installation Type D: ducted inlet/ducted outlet. Power rating (BHP) does not include drive losses. Performance data is based on standard air conditions (0.075 #/ft.3). Performance ratings do not include the effects of appurtenances in the airstream. MOST EFFICIENT FAN SELECTION APPEARS IN BOLD PRINT. To complete model code, add arrangement, class of construction, material code, motor enclosure code, motor horsepower code and motor speed code. Refer to page 2 for more information.



Rating Tables

Class I Class II Class III

Size 33, Type BC, A04- -33_ BC100

Wheel Diameter: 33.00"
Outlet Area: 11.17 Sq. Ft.

CFM	Outlet Velocity FPM	Static Pressure															
		1/2"		1"		1 1/2"		2"		2 1/2"		3"		3 1/2"		4"	
		RPM	BHP	RPM	BHP	RPM	BHP	RPM	BHP	RPM	BHP	RPM	BHP	RPM	BHP	RPM	BHP
6000	537	411	0.75	525	1.46												
8000	716	480	1.18	567	1.97	652	2.88										
10000	895	561	1.81	630	2.70	700	3.72	767	4.80	837	6.02						
12000	1074	659	2.85	707	3.73	764	4.81	822	6.03	878	7.29	934	8.63	993	10.1	1051	11.7
14000	1254	751	4.12	787	5.02	837	6.24	886	7.53	937	8.94	986	10.4	1034	11.9	1082	13.4
16000	1433	832	5.45	884	6.94	916	7.99	960	9.42	1003	10.9	1048	12.5	1091	14.1	1133	15.8
18000	1612	923	7.36	982	9.33	1004	10.3	1039	11.8	1078	13.3	1115	14.9	1155	16.7	1195	18.5
20000	1791	1017	9.71	1071	11.9	1103	13.4	1123	14.5	1158	16.3	1192	18.0	1225	19.7	1260	21.6
22000	1970	1111	12.5	1148	14.4	1200	17.1	1220	18.3	1239	19.6	1272	21.5	1304	23.5	1333	25.3
24000	2149	1205	15.9	1239	17.9	1291	20.9	1319	22.8	1334	24.1	1352	25.5	1382	27.6	1414	29.8
26000	2328	1300	19.8	1331	22.0	1370	24.7	1414	27.8	1433	29.4	1447	30.8	1464	32.3	1490	34.5
28000	2507	1396	24.4	1425	26.7	1453	29.1	1503	33.0	1531	35.4	1546	37.0	1559	38.5	1575	40.1
30000	2686	1491	29.6	1518	32.2	1545	34.6	1581	37.9	1623	41.8	1645	44.1	1658	45.7	1670	47.3
32000	2865	1587	35.6	1613	38.3	1638	40.9	1663	43.6	1709	48.3	1739	51.6	1757	53.9	1769	55.6
CFM	OV FPM	5"		6"		7"		8"		9"		10"		12"		14"	
		RPM	BHP	RPM	BHP	RPM	BHP	RPM	BHP	RPM	BHP	RPM	BHP	RPM	BHP	RPM	BHP
		15000	1343	1197	18.0	1290	21.8										
16500	1477	1230	19.9	1313	23.7	1397	27.9										
18000	1612	1270	22.2	1345	26.1	1421	30.2	1499	34.7	1576	39.4						
19500	1746	1316	24.8	1385	28.8	1455	33.0	1524	37.4	1596	42.2	1667	47.2				
21000	1880	1364	27.6	1430	31.8	1495	36.1	1559	40.7	1623	45.4	1689	50.4	1822	61.1		
22500	2015	1414	30.5	1478	35.1	1539	39.6	1599	44.3	1659	49.1	1719	54.1	1842	64.9	1967	76.5
24000	2149	1468	33.8	1527	38.5	1586	43.4	1644	48.3	1700	53.2	1756	58.3	1869	69.1	1985	80.8
25500	2283	1527	37.8	1579	42.3	1635	47.4	1691	52.5	1745	57.7	1798	63.0	1904	73.9	2010	85.6
27000	2418	1588	42.2	1635	46.6	1686	51.6	1740	57.1	1792	62.5	1843	68.0	1943	79.3	2043	91.0
28500	2552	1645	46.6	1695	51.6	1740	56.4	1790	61.9	1841	67.7	1890	73.4	1986	85.0	2081	97.1
30000	2686	1703	51.2	1757	57.1	1799	61.9	1843	67.1	1891	73.0	1939	79.1	2032	91.2		
31500	2821	1769	56.9	1812	62.2	1860	68.0	1901	73.2	1944	78.8	1989	84.9	2079	97.7		
33000	2955	1841	63.5	1872	67.9	1921	74.4	1961	79.9	2000	85.3	2041	91.3				
34500	3089	1914	70.9	1938	74.7	1975	80.3	2023	87.1	2060	92.7	2097	98.5				

Size 33, Type BA, A04- -33_ BA100

Wheel Diameter: 33.00"
Outlet Area: 11.17 Sq. Ft.

CFM	Outlet Velocity FPM	Static Pressure															
		1/2"		1"		1 1/2"		2"		2 1/2"		3"		3 1/2"		4"	
		RPM	BHP	RPM	BHP	RPM	BHP	RPM	BHP	RPM	BHP	RPM	BHP	RPM	BHP	RPM	BHP
6000	537	422	0.69	530	1.31												
8000	716	497	1.09	581	1.82	663	2.63	741	3.50								
10000	895	583	1.68	650	2.51	718	3.43	785	4.43	848	5.47	911	6.56				
12000	1074	675	2.50	732	3.44	787	4.46	844	5.56	900	6.73	955	7.95	1008	9.20	1060	10.5
14000	1254	768	3.56	818	4.65	867	5.78	915	6.97	963	8.24	1011	9.58	1059	11.0	1106	12.4
16000	1433	864	4.94	909	6.19	952	7.42	995	8.74	1036	10.1	1078	11.5	1121	13.0	1163	14.5
18000	1612	961	6.69	1002	8.06	1041	9.46	1079	10.9	1117	12.3	1153	13.9	1190	15.4	1228	17.1
20000	1791	1059	8.83	1096	10.3	1132	11.9	1166	13.4	1201	15.0	1235	16.7	1268	18.3	1301	20.0
22000	1970	1158	11.4	1192	13.0	1225	14.7	1257	16.5	1288	18.1	1319	19.9	1350	21.7	1381	23.5
24000	2149	1258	14.5	1288	16.2	1319	18.1	1349	20.0	1378	21.8	1406	23.6	1435	25.5	1464	27.5
26000	2328	1358	18.1	1386	20.0	1414	21.9	1442	23.9	1470	26.0	1496	28.0	1522	30.0	1549	32.0
28000	2507	1458	22.3	1484	24.3	1510	26.4	1537	28.5	1563	30.7	1588	32.9	1612	35.0	1636	37.2
30000	2686	1559	27.2	1583	29.3	1607	31.4	1632	33.7	1656	36.0	1680	38.4	1704	40.8	1727	43.0
32000	2865	1660	32.7	1682	34.9	1705	37.2	1728	39.5	1751	42.0	1774	44.5	1796	47.0	1818	49.5
CFM	OV FPM	5"		6"		7"		8"		9"		10"		12"		14"	
		RPM	BHP	RPM	BHP	RPM	BHP	RPM	BHP	RPM	BHP	RPM	BHP	RPM	BHP	RPM	BHP
		15000	1343	1220	16.5	1304	19.7	1386	23.0								
16500	1477	1260	18.4	1338	21.8	1414	25.3	1490	28.9								
18000	1612	1303	20.5	1378	24.1	1450	27.8	1520	31.5	1589	35.4	1658	39.4				
19500	1746	1352	22.8	1421	26.6	1490	30.5	1556	34.4	1622	38.5	1686	42.6	1813	51.3		
21000	1880	1404	25.4	1469	29.3	1533	33.3	1597	37.5	1659	41.8	1720	46.1	1839	55.1		
22500	2015	1460	28.3	1520	32.3	1581	36.5	1641	40.9	1700	45.3	1758	49.9	1872	59.2	1983	68.8
24000	2149	1519	31.5	1575	35.7	1631	40.0	1688	44.5	1744	49.1	1800	53.9	1909	63.6	2015	73.6
25500	2283	1581	35.0	1633	39.3	1685	43.8	1738	48.4	1792	53.2	1845	58.1	1950	68.3	2051	78.7
27000	2418	1643	38.9	1693	43.4	1742	48.0	1792	52.7	1842	57.6	1893	62.7	1993	73.2	2091	84.0
28500	2552	1707	43.1	1755	47.8	1802	52.5	1848	57.4	1895	62.4	1943	67.6	2039	78.4		
30000	2686	1772	47.6	1818	52.5	1863	57.5	1907	62.5	1951	67.7	1996	73.0	2087	84.0		
31500	2821	1838	52.6	1882	57.6	1926	62.7	1969	68.0	2010	73.3	2052	78.7				
33000	2955	1906	58.1	1947	63.1	1989	68.4	2031	73.9	2071	79.4						
34500	3089	1974	63.9	2014	69.2	2053	74.6	2093	80.2								

Performance shown is for installation Type D: ducted inlet/ducted outlet. Power rating (BHP) does not include drive losses. Performance data is based on standard air conditions (0.075 #/ft.3). Performance ratings do not include the effects of appurtenances in the airstream. **MOST EFFICIENT FAN SELECTION APPEARS IN BOLD PRINT.** To complete model code, add arrangement, class of construction, material code, motor enclosure code, motor horsepower code and motor speed code. Refer to page 2 for more information.



Rating Tables

Class I

Class II

Class III

Size 36, Type BC, A04- -36_BC100

Wheel Diameter: 36.00"
Outlet Area: 13.30 Sq. Ft.

CFM	Outlet Velocity FPM	Static Pressure															
		1/2"		1"		1 1/2"		2"		2 1/2"		3"		3 1/2"		4"	
		RPM	BHP	RPM	BHP	RPM	BHP	RPM	BHP	RPM	BHP	RPM	BHP	RPM	BHP	RPM	BHP
7500	564	385	0.96	485	1.81												
10000	752	455	1.54	530	2.50	604	3.60	680	4.87								
12500	940	537	2.43	594	3.47	655	4.73	715	6.05	774	7.50	835	9.10				
15000	1128	631	3.83	670	4.87	719	6.18	771	7.69	820	9.23	869	10.9	919	12.6	970	14.5
17500	1316	715	5.43	752	6.70	794	8.16	835	9.67	880	11.4	923	13.2	965	15.0	1007	16.9
20000	1504	796	7.34	847	9.37	870	10.5	910	12.3	946	14.0	985	16.0	1023	18.0	1061	20.0
22500	1692	885	9.96	938	12.5	962	13.9	985	15.3	1022	17.4	1053	19.3	1087	21.4	1122	23.7
25000	1880	975	13.2	1018	15.7	1057	18.1	1073	19.4	1096	21.1	1131	23.5	1159	25.6	1188	27.8
27500	2068	1066	17.1	1098	19.3	1147	22.8	1168	24.7	1183	26.1	1204	28.0	1237	30.8	1263	33.0
30000	2256	1157	21.7	1187	24.2	1229	27.6	1262	30.7	1278	32.4	1291	33.9	1311	36.0	1340	38.9
32500	2444	1249	27.1	1276	29.8	1303	32.5	1350	37.1	1373	39.7	1386	41.4	1398	43.1	1415	45.2
35000	2632	1341	33.3	1366	36.3	1391	39.2	1429	43.4	1464	47.5	1481	50.0	1493	51.8	1504	53.6
37500	2820	1433	40.5	1457	43.7	1480	46.8	1504	50.0	1548	55.6	1573	59.2	1589	61.7	1599	63.6
40000	3008	1526	48.7	1548	52.1	1570	55.4	1592	58.7	1623	63.3	1660	68.9	1681	72.4	1695	74.9
CFM	OV FPM	5"		6"		7"		8"		9"		10"		12"		14"	
		RPM	BHP	RPM	BHP	RPM	BHP	RPM	BHP	RPM	BHP	RPM	BHP	RPM	BHP	RPM	BHP
		18000	1354	1099	21.6	1184	26.1										
19500	1466	1125	23.5	1201	28.1	1280	33.0										
21000	1579	1155	25.8	1225	30.3	1297	35.3	1369	40.6								
22500	1692	1189	28.2	1255	32.9	1320	37.9	1387	43.2	1455	48.8	1522	54.7				
24000	1805	1225	30.9	1288	35.8	1349	40.9	1410	46.2	1473	51.8	1537	57.8				
25500	1918	1263	33.8	1323	38.9	1381	44.1	1439	49.6	1497	55.2	1555	61.1	1675	74.0		
27000	2031	1302	36.8	1360	42.2	1416	47.7	1471	53.3	1525	59.0	1580	65.0	1691	77.8	1804	91.7
28500	2143	1344	40.1	1398	45.7	1453	51.5	1505	57.3	1557	63.2	1609	69.2	1712	82.0	1819	96.0
30000	2256	1389	44.0	1438	49.4	1490	55.5	1541	61.5	1591	67.6	1640	73.8	1738	86.8	1838	101
31500	2369	1435	48.3	1480	53.5	1529	59.6	1579	66.0	1627	72.3	1674	78.8	1768	92.0	1861	106
33000	2482	1483	52.9	1525	58.3	1569	64.1	1617	70.6	1664	77.4	1710	84.0	1800	97.6	1889	112
34500	2595	1524	57.1	1572	63.5	1613	69.2	1656	75.6	1702	82.5	1747	89.5	1834	104	1920	118
36000	2707	1571	62.0	1620	69.0	1659	74.9	1698	81.0	1741	87.9	1785	95.3	1869	110		
37500	2820	1622	67.7	1662	74.0	1706	81.0	1743	87.1	1782	93.8	1823	101	1906	116		

Size 36, Type BA, A04- -36_BA100

Wheel Diameter: 36.00"
Outlet Area: 13.30 Sq. Ft.

CFM	Outlet Velocity FPM	Static Pressure															
		1/2"		1"		1 1/2"		2"		2 1/2"		3"		3 1/2"		4"	
		RPM	BHP	RPM	BHP	RPM	BHP	RPM	BHP	RPM	BHP	RPM	BHP	RPM	BHP	RPM	BHP
7500	564	396	0.89	491	1.64												
10000	752	471	1.42	545	2.31	617	3.31	685	4.37								
12500	940	555	2.22	614	3.23	673	4.36	732	5.59	788	6.87	843	8.20				
15000	1128	644	3.32	694	4.49	743	5.74	792	7.08	841	8.52	890	10.0	937	11.6	983	13.1
17500	1316	735	4.77	779	6.13	822	7.52	863	8.99	905	10.5	948	12.2	990	13.9	1031	15.6
20000	1504	828	6.66	867	8.22	905	9.75	942	11.4	979	13.0	1015	14.8	1052	16.6	1089	18.5
22500	1692	922	9.05	957	10.7	992	12.5	1025	14.2	1058	16.1	1091	17.9	1123	19.9	1155	21.9
25000	1880	1016	12.0	1049	13.8	1080	15.8	1111	17.7	1140	19.7	1170	21.7	1200	23.8	1229	25.9
27500	2068	1112	15.6	1141	17.5	1170	19.7	1199	21.8	1226	23.9	1253	26.0	1280	28.3	1308	30.5
30000	2256	1208	19.8	1235	21.9	1262	24.2	1288	26.5	1314	28.9	1339	31.2	1363	33.5	1388	35.9
32500	2444	1305	24.8	1329	27.1	1354	29.5	1379	31.9	1403	34.5	1426	37.1	1449	39.5	1472	42.0
35000	2632	1402	30.5	1424	33.0	1447	35.5	1470	38.2	1493	40.9	1515	43.7	1537	46.4	1558	49.1
37500	2820	1499	37.2	1519	39.8	1541	42.5	1562	45.3	1584	48.1	1605	51.1	1626	54.1	1646	57.0
40000	3008	1596	44.8	1615	47.6	1635	50.4	1655	53.3	1676	56.3	1696	59.4	1715	62.6	1735	65.7
CFM	OV FPM	5"		6"		7"		8"		9"		10"		12"		14"	
		RPM	BHP	RPM	BHP	RPM	BHP	RPM	BHP	RPM	BHP	RPM	BHP	RPM	BHP	RPM	BHP
		18000	1354	1121	19.8	1197	23.6	1273	27.6								
19500	1466	1152	21.7	1224	25.7	1294	29.8	1364	34.1								
21000	1579	1185	23.8	1254	28.0	1321	32.3	1386	36.7	1451	41.3						
22500	1692	1221	26.0	1287	30.4	1351	34.9	1413	39.6	1474	44.3	1535	49.2				
24000	1805	1260	28.5	1322	33.0	1383	37.7	1443	42.6	1501	47.5	1559	52.5	1672	63.0		
25500	1918	1301	31.2	1359	35.8	1417	40.7	1475	45.8	1531	50.9	1586	56.1	1694	66.9	1800	78.1
27000	2031	1345	34.1	1399	38.9	1454	43.9	1509	49.1	1563	54.5	1616	59.9	1720	71.1	1821	82.6
28500	2143	1391	37.4	1442	42.3	1494	47.4	1546	52.8	1597	58.3	1649	63.9	1749	75.5	1846	87.4
30000	2256	1438	40.9	1486	45.9	1535	51.2	1584	56.7	1634	62.3	1683	68.1	1780	80.1	1874	92.4
31500	2369	1486	44.6	1532	49.9	1578	55.3	1625	60.9	1672	66.6	1719	72.6	1812	85.0	1903	97.7
33000	2482	1535	48.6	1580	54.1	1623	59.7	1667	65.4	1712	71.3	1757	77.4	1847	90.0		
34500	2595	1584	53.0	1628	58.6	1670	64.4	1712	70.2	1754	76.3	1797	82.5	1883	95.4		
36000	2707	1634	57.6	1676	63.4	1718	69.4	1758	75.4	1798	81.6	1838	88.0	1921	101		
37500	2820	1686	62.7	1726	68.6	1766	74.7	1805	81.0	1843	87.3	1882	93.8				

Performance shown is for installation Type D: ducted inlet/ducted outlet. Power rating (BHP) does not include drive losses. Performance data is based on standard air conditions (0.075 #/ft.3). Performance ratings do not include the effects of appurtenances in the airstream. MOST EFFICIENT FAN SELECTION APPEARS IN BOLD PRINT. To complete model code, add arrangement, class of construction, material code, motor enclosure code, motor horsepower code and motor speed code. Refer to page 2 for more information.



Rating Tables

Class I Class II Class III

Size 40, Type BC, A04- -40 BC100

Wheel Diameter: 40.25"
Outlet Area: 16.61 Sq. Ft.

CFM	Outlet Velocity FPM	Static Pressure															
		1/2"		1"		1 1/2"		2"		2 1/2"		3"		3 1/2"		4"	
		RPM	BHP	RPM	BHP	RPM	BHP	RPM	BHP	RPM	BHP	RPM	BHP	RPM	BHP	RPM	BHP
9000	542	338	1.13	431	2.18												
12000	722	396	1.78	466	2.96	535	4.32										
15000	903	463	2.75	519	4.07	576	5.59	631	7.21	687	9.03						
18000	1084	545	4.33	583	5.64	629	7.25	676	9.07	722	11.0	768	13.0	815	15.1	862	17.5
21000	1264	620	6.24	650	7.60	690	9.43	730	11.3	771	13.5	811	15.6	850	17.8	889	20.2
24000	1445	687	8.28	731	10.5	755	12.1	792	14.2	826	16.4	863	18.8	898	21.2	932	23.7
27000	1625	763	11.2	811	14.2	830	15.7	857	17.7	889	20.1	919	22.5	951	25.2	983	27.9
30000	1806	840	14.8	884	18.0	911	20.4	927	22.0	954	24.5	983	27.2	1009	29.7	1038	32.6
33000	1987	918	19.1	948	21.9	991	25.9	1007	27.8	1022	29.6	1048	32.5	1075	35.5	1099	38.2
36000	2167	996	24.2	1023	27.2	1065	31.7	1089	34.7	1102	36.5	1116	38.6	1139	41.6	1166	45.1
39000	2348	1075	30.2	1100	33.4	1130	37.3	1167	42.1	1184	44.7	1195	46.7	1209	49.0	1229	52.1
42000	2528	1153	37.2	1177	40.7	1200	44.2	1240	49.9	1264	53.8	1277	56.3	1288	58.4	1300	60.8
45000	2709	1232	45.1	1255	48.9	1276	52.6	1304	57.3	1340	63.4	1358	67.0	1369	69.5	1379	71.8
48000	2889	1312	54.2	1333	58.3	1353	62.2	1373	66.2	1410	73.1	1436	78.3	1451	81.8	1461	84.4
CFM	OV FPM	5"		6"		7"		8"		9"		10"		12"		14"	
		RPM	BHP	RPM	BHP	RPM	BHP	RPM	BHP	RPM	BHP	RPM	BHP	RPM	BHP	RPM	BHP
		22000	1324	978	26.4	1056	32.0										
24000	1445	1001	28.9	1071	34.6	1142	40.7										
26000	1565	1029	31.8	1093	37.5	1157	43.7	1223	50.3								
28000	1686	1061	35.1	1120	41.0	1179	47.1	1239	53.7	1300	60.8	1361	68.2				
30000	1806	1096	38.6	1152	44.8	1207	51.1	1261	57.7	1317	64.7	1374	72.2				
32000	1926	1132	42.4	1185	48.9	1237	55.5	1289	62.3	1340	69.3	1392	76.7	1499	92.8		
34000	2047	1169	46.5	1221	53.4	1271	60.2	1320	67.2	1368	74.4	1416	81.9	1515	97.9	1615	115
36000	2167	1209	51.1	1257	58.0	1306	65.3	1352	72.6	1399	80.0	1444	87.7	1536	104	1630	121
38000	2288	1253	56.4	1296	63.1	1342	70.7	1387	78.4	1431	86.1	1475	93.9	1562	110	1649	128
40000	2408	1298	62.3	1337	68.8	1379	76.3	1423	84.4	1466	92.5	1508	101	1591	117	1673	135
42000	2528	1341	68.2	1381	75.4	1419	82.6	1460	90.7	1502	99.3	1542	108	1622	125	1700	143
44000	2649	1382	74.1	1426	82.5	1461	89.7	1499	97.6	1538	106	1578	115	1655	133		
46000	2769	1429	81.2	1469	89.6	1506	97.6	1540	105	1576	114	1615	123	1690	142		
48000	2889	1480	89.4	1510	96.6	1551	106	1583	114	1617	122	1652	131				

Size 40, Type BA, A04- -40 BA100

Wheel Diameter: 40.25"
Outlet Area: 16.61 Sq. Ft.

CFM	Outlet Velocity FPM	Static Pressure															
		1/2"		1"		1 1/2"		2"		2 1/2"		3"		3 1/2"		4"	
		RPM	BHP	RPM	BHP	RPM	BHP	RPM	BHP	RPM	BHP	RPM	BHP	RPM	BHP	RPM	BHP
9000	542	347	1.05	435	1.97												
12000	722	410	1.65	478	2.73	545	3.95	608	5.25								
15000	903	481	2.54	536	3.78	591	5.16	645	6.65	697	8.21	748	9.84				
18000	1084	557	3.78	603	5.19	649	6.72	695	8.36	740	10.1	785	11.9	828	13.8	870	15.7
21000	1264	634	5.40	675	7.03	715	8.73	753	10.5	793	12.4	832	14.4	871	16.5	909	18.6
24000	1445	714	7.51	750	9.38	785	11.2	820	13.2	853	15.2	888	17.4	922	19.6	957	21.9
27000	1625	794	10.2	827	12.2	859	14.3	890	16.4	921	18.6	950	20.9	980	23.3	1011	25.7
30000	1806	875	13.4	905	15.7	934	18.0	962	20.3	990	22.7	1018	25.1	1045	27.7	1072	30.2
33000	1987	957	17.4	984	19.8	1011	22.3	1037	24.9	1062	27.4	1088	30.0	1113	32.8	1138	35.5
36000	2167	1039	22.1	1064	24.7	1089	27.4	1114	30.3	1137	33.0	1160	35.8	1183	38.6	1207	41.5
39000	2348	1122	27.6	1145	30.4	1168	33.3	1191	36.3	1213	39.4	1235	42.4	1256	45.4	1277	48.4
42000	2528	1205	34.0	1226	37.0	1248	40.0	1269	43.2	1290	46.5	1311	49.9	1331	53.1	1350	56.3
45000	2709	1288	41.4	1308	44.5	1328	47.8	1348	51.1	1368	54.6	1387	58.2	1406	61.7	1425	65.2
48000	2889	1372	49.7	1390	53.1	1408	56.5	1427	60.0	1446	63.7	1465	67.5	1483	71.3	1501	75.1
CFM	OV FPM	5"		6"		7"		8"		9"		10"		12"		14"	
		RPM	BHP	RPM	BHP	RPM	BHP	RPM	BHP	RPM	BHP	RPM	BHP	RPM	BHP	RPM	BHP
		22000	1324	996	24.2	1065	28.8										
24000	1445	1024	26.7	1090	31.6	1153	36.7	1216	42.0								
26000	1565	1056	29.4	1118	34.6	1178	40.0	1237	45.5	1295	51.2						
28000	1686	1090	32.3	1149	37.8	1206	43.4	1262	49.2	1317	55.1	1371	61.2				
30000	1806	1127	35.6	1182	41.3	1237	47.2	1290	53.2	1343	59.4	1394	65.7	1495	78.7		
32000	1926	1166	39.2	1218	45.0	1270	51.2	1321	57.5	1371	63.9	1421	70.5	1517	84.0	1611	98.0
34000	2047	1208	43.2	1257	49.2	1305	55.5	1354	62.0	1402	68.7	1450	75.6	1542	89.6	1632	104
36000	2167	1252	47.5	1297	53.7	1343	60.2	1389	66.9	1435	73.8	1481	80.9	1570	95.5	1656	110
38000	2288	1298	52.3	1340	58.7	1383	65.3	1426	72.2	1470	79.3	1514	86.6	1599	102	1683	117
40000	2408	1344	57.4	1385	64.1	1425	70.9	1466	77.9	1507	85.2	1549	92.7	1631	108	1712	124
42000	2528	1390	62.9	1430	69.8	1468	76.9	1507	84.1	1546	91.6	1586	99.2	1664	115		
44000	2649	1438	68.9	1476	76.0	1513	83.3	1550	90.8	1587	98.4	1624	106	1700	123		
46000	2769	1486	75.3	1523	82.7	1559	90.2	1594	97.9	1629	106	1665	114				
48000	2889	1535	82.3	1570	89.8	1605	97.6	1640	106	1673	114	1707	122				

Performance shown is for installation Type D: ducted inlet/ducted outlet. Power rating (BHP) does not include drive losses. Performance data is based on standard air conditions (0.075 #/ft.3). Performance ratings do not include the effects of appurtenances in the airstream. MOST EFFICIENT FAN SELECTION APPEARS IN BOLD PRINT. To complete model code, add arrangement, class of construction, material code, motor enclosure code, motor horsepower code and motor speed code. Refer to page 2 for more information.



Rating Tables

Class I

Class II

Class III

Size 44, Type BC, A04- -44_BC100

Wheel Diameter: 45.50"
Outlet Area: 20.30 Sq. Ft.

CFM	Outlet Velocity FPM	Static Pressure															
		1/2"		1"		1 1/2"		2"		2 1/2"		3"		3 1/2"		4"	
		RPM	BHP	RPM	BHP	RPM	BHP	RPM	BHP	RPM	BHP	RPM	BHP	RPM	BHP	RPM	BHP
12000	591	319	1.57	396	2.88												
16000	788	380	2.57	438	4.08	495	5.78	554	7.73								
20000	985	452	4.16	494	5.75	542	7.71	588	9.78	633	12.0	680	14.5				
24000	1183	531	6.55	558	8.07	598	10.2	638	12.6	676	15.0	714	17.5	752	20.2	791	23.0
28000	1380	597	9.07	634	11.5	663	13.6	695	16.0	729	18.7	763	21.5	796	24.4	828	27.3
32000	1577	671	12.6	714	16.1	731	17.8	760	20.6	788	23.2	817	26.2	847	29.4	876	32.6
36000	1774	747	17.2	788	21.2	811	23.8	826	25.8	853	29.1	878	32.1	903	35.2	930	38.7
40000	1971	824	22.8	851	26.2	890	31.0	904	33.3	919	35.6	943	39.1	967	42.7	989	46.0
44000	2168	901	29.6	925	33.2	964	38.7	985	42.4	997	44.6	1010	47.2	1030	50.9	1055	55.1
48000	2365	978	37.6	1001	41.6	1027	46.2	1062	52.4	1078	55.6	1088	58.1	1099	60.8	1117	64.5
52000	2562	1056	47.1	1077	51.4	1098	55.7	1133	62.7	1156	67.9	1169	71.1	1178	73.7	1188	76.6
56000	2759	1134	58.0	1154	62.8	1173	67.4	1195	72.6	1230	80.8	1248	85.6	1259	88.9	1268	91.7
60000	2956	1212	70.6	1231	75.7	1249	80.7	1267	85.7	1296	93.4	1323	101	1339	106	1348	109
64000	3153	1291	85.0	1308	90.4	1325	95.7	1342	101	1359	106	1392	116	1414	123	1428	128
CFM	OV FPM	5"		6"		7"		8"		9"		10"		12"		14"	
27500	1355	889	33.0	958	39.9												
30000	1478	912	36.3	973	43.2	1036	50.7										
32500	1601	939	40.0	995	47.0	1052	54.6	1110	62.7	1168	71.2						
35000	1725	970	44.2	1022	51.5	1074	59.1	1127	67.1	1180	75.8	1234	84.8				
37500	1848	1002	48.8	1052	56.4	1101	64.2	1149	72.4	1198	80.9	1248	90.1	1349	110		
40000	1971	1036	53.6	1084	61.7	1130	69.9	1176	78.2	1221	86.9	1267	96.0	1361	116		
42500	2094	1071	58.9	1117	67.4	1161	76.0	1205	84.6	1248	93.6	1290	103	1377	122	1466	144
45000	2217	1110	65.0	1151	73.4	1195	82.5	1236	91.6	1277	101	1317	110	1398	130	1481	151
47500	2340	1151	72.0	1188	80.0	1228	89.3	1269	98.9	1308	109	1347	118	1423	138	1500	160
50000	2464	1193	79.6	1227	87.7	1263	96.6	1302	107	1341	117	1378	127	1451	148	1524	169
52500	2587	1230	86.6	1268	96.3	1301	105	1337	115	1374	125	1410	136	1481	157	1550	179
55000	2710	1271	94.7	1310	105	1342	114	1374	124	1408	134	1444	146	1512	168		
57500	2833	1316	104	1347	114	1383	125	1413	134	1445	144	1478	155	1545	179		
60000	2956	1365	115	1388	123	1425	135	1454	145	1483	155	1514	166				

Size 44, Type BA, A04- -44_BA100

Wheel Diameter: 44.50"
Outlet Area: 20.30 Sq. Ft.

CFM	Outlet Velocity FPM	Static Pressure															
		1/2"		1"		1 1/2"		2"		2 1/2"		3"		3 1/2"		4"	
		RPM	BHP	RPM	BHP	RPM	BHP	RPM	BHP	RPM	BHP	RPM	BHP	RPM	BHP	RPM	BHP
12000	591	328	1.45	403	2.63												
16000	788	394	2.37	450	3.76	507	5.33	560	7.00								
20000	985	466	3.74	512	5.35	557	7.11	603	9.03	647	11.0	690	13.1	732	15.3		
24000	1183	542	5.64	581	7.50	619	9.48	656	11.6	694	13.8	732	16.2	769	18.6	805	21.1
28000	1380	619	8.16	654	10.4	687	12.5	719	14.9	751	17.3	784	19.8	817	22.5	849	25.2
32000	1577	698	11.5	729	13.9	758	16.4	787	18.9	816	21.6	843	24.3	872	27.1	901	30.1
36000	1774	778	15.6	806	18.3	833	21.2	858	23.9	884	26.8	910	29.7	934	32.8	959	35.9
40000	1971	859	20.8	884	23.7	908	26.8	932	29.9	955	33.0	978	36.1	1001	39.4	1024	42.8
44000	2168	940	27.0	962	30.2	985	33.5	1007	37.0	1028	40.4	1049	43.7	1070	47.2	1092	50.8
48000	2365	1022	34.4	1042	37.8	1063	41.3	1083	45.1	1104	48.9	1123	52.6	1142	56.2	1161	60.0
52000	2562	1104	43.1	1122	46.8	1141	50.6	1161	54.5	1179	58.6	1198	62.7	1216	66.7	1233	70.6
56000	2759	1186	53.2	1203	57.2	1221	61.2	1239	65.3	1256	69.6	1274	74.1	1291	78.5	1307	82.8
60000	2956	1268	64.8	1284	69.0	1300	73.3	1317	77.7	1334	82.2	1350	86.9	1366	91.6	1382	96.4
64000	3153	1350	78.1	1365	82.6	1381	87.1	1396	91.7	1412	96.4	1428	101	1443	106	1458	111
CFM	OV FPM	5"		6"		7"		8"		9"		10"		12"		14"	
27500	1355	907	30.3	969	36.1	1030	42.1										
30000	1478	934	33.5	992	39.6	1049	45.9	1105	52.5								
32500	1601	964	36.9	1019	43.4	1073	50.1	1125	56.9	1177	63.9	1228	71.2				
35000	1725	996	40.7	1048	47.5	1099	54.5	1149	61.7	1198	69.0	1246	76.5				
37500	1848	1031	45.0	1080	52.0	1129	59.3	1176	66.8	1223	74.4	1269	82.2	1359	98.4		
40000	1971	1068	49.6	1114	56.8	1160	64.4	1205	72.2	1250	80.2	1294	88.4	1380	105	1464	122
42500	2094	1108	54.8	1150	62.2	1194	70.0	1237	78.0	1279	86.4	1322	94.9	1404	112	1484	130
45000	2217	1149	60.4	1189	68.1	1229	76.1	1270	84.3	1311	92.9	1351	102	1430	120	1507	138
47500	2340	1192	66.5	1229	74.5	1267	82.7	1305	91.2	1344	100.0	1382	109	1459	128	1533	147
50000	2464	1234	73.1	1271	81.4	1306	89.9	1342	98.6	1379	108	1416	117	1489	136		
52500	2587	1278	80.3	1313	88.9	1347	97.7	1381	107	1416	116	1451	125	1520	145		
55000	2710	1322	88.0	1356	96.9	1389	106	1422	115	1454	125	1487	134	1554	154		
57500	2833	1367	96.5	1399	106	1432	115	1463	124	1494	134	1525	144				
60000	2956	1413	106	1444	115	1475	124	1506	134	1536	144						

Performance shown is for installation Type D: ducted inlet/ducted outlet. Power rating (BHP) does not include drive losses. Performance data is based on standard air conditions (0.075 #/ft.3). Performance ratings do not include the effects of appurtenances in the airstream. MOST EFFICIENT FAN SELECTION APPEARS IN BOLD PRINT. To complete model code, add arrangement, class of construction, material code, motor enclosure code, motor horsepower code and motor speed code. Refer to page 2 for more information.



Rating Tables

Class I Class II Class III

Size 49, Type BC, A04- -49_ BC100

Wheel Diameter: 49.00"
Outlet Area: 24.62 Sq. Ft.

CFM	Outlet Velocity FPM	Static Pressure															
		1/2"		1"		1 1/2"		2"		2 1/2"		3"		3 1/2"		4"	
		RPM	BHP	RPM	BHP	RPM	BHP	RPM	BHP	RPM	BHP	RPM	BHP	RPM	BHP	RPM	BHP
15000	609	294	1.99	362	3.60												
20000	812	352	3.28	404	5.17	454	7.26	505	9.62								
25000	1015	422	5.44	458	7.37	500	9.78	540	12.3	580	15.0	621	18.0	663	21.2		
30000	1218	495	8.52	518	10.4	553	13.0	588	15.9	623	18.9	656	22.1	690	25.3	723	28.8
35000	1422	556	11.8	591	15.0	613	17.4	643	20.5	673	23.7	703	27.2	732	30.8	761	34.4
40000	1625	626	16.6	666	21.0	681	23.2	704	26.3	730	29.8	755	33.3	781	37.3	808	41.3
45000	1828	698	22.6	732	27.4	757	31.2	769	33.5	790	37.1	814	41.2	835	44.9	858	49.2
50000	2031	770	30.0	794	34.2	830	40.5	844	43.6	855	46.2	873	50.1	897	54.9	916	59.0
55000	2234	842	39.0	864	43.6	896	50.1	919	55.4	930	58.4	940	61.3	955	65.3	978	70.9
60000	2437	915	49.7	935	54.7	955	59.7	989	68.2	1006	72.8	1015	76.0	1024	79.1	1037	83.2
65000	2640	988	62.2	1006	67.6	1024	73.0	1052	80.8	1077	88.5	1091	93.1	1099	96.5	1108	99.8
70000	2843	1061	76.7	1078	82.7	1095	88.4	1112	94.3	1144	105	1163	112	1175	116	1183	120
75000	3046	1134	93.5	1150	99.8	1166	106	1182	112	1203	120	1232	131	1248	138	1259	143
80000	3249	1208	112	1223	119	1238	126	1253	133	1268	139	1293	150	1317	161	1332	168
CFM	OV FPM	5"		6"		7"		8"		9"		10"		12"		14"	
		RPM	BHP	RPM	BHP	RPM	BHP	RPM	BHP	RPM	BHP	RPM	BHP	RPM	BHP	RPM	BHP
		33000	1340	806	39.6	869	48.0										
36000	1462	825	43.4	882	51.8	940	60.9										
39000	1584	850	47.9	901	56.4	953	65.5	1007	75.3								
42000	1706	877	52.9	925	61.6	972	70.8	1021	80.6	1070	91.0	1120	102				
45000	1828	906	58.3	951	67.4	996	76.9	1040	86.7	1085	97.1	1131	108				
48000	1950	936	64.0	979	73.7	1022	83.5	1063	93.6	1105	104	1147	115	1234	139		
51000	2071	967	70.2	1009	80.5	1050	90.8	1089	101	1129	112	1168	123	1248	147	1329	173
54000	2193	1001	77.3	1040	87.5	1079	98.5	1117	109	1155	121	1192	132	1266	156	1342	182
57000	2315	1038	85.5	1072	95.3	1109	107	1146	118	1182	130	1218	141	1288	166	1359	191
60000	2437	1075	94.5	1107	104	1141	115	1176	127	1211	139	1245	152	1313	177	1379	203
63000	2559	1110	103	1144	114	1174	125	1207	137	1241	150	1274	162	1339	188	1403	215
66000	2681	1145	112	1181	125	1210	136	1240	147	1272	160	1305	174	1367	200		
69000	2802	1185	124	1215	136	1247	148	1275	159	1304	172	1335	185	1396	213		
72000	2924	1228	136	1251	147	1285	161	1311	173	1338	185	1366	198				

Size 49, Type BA, A04- -49_ BA100

Wheel Diameter: 49.00"
Outlet Area: 24.62 Sq. Ft.

CFM	Outlet Velocity FPM	Static Pressure															
		1/2"		1"		1 1/2"		2"		2 1/2"		3"		3 1/2"		4"	
		RPM	BHP	RPM	BHP	RPM	BHP	RPM	BHP	RPM	BHP	RPM	BHP	RPM	BHP	RPM	BHP
10000	406	256	1.10														
15000	609	303	1.84	369	3.30												
20000	812	365	3.04	415	4.76	465	6.70	513	8.76	559	10.9						
25000	1015	434	4.85	474	6.84	514	9.01	554	11.4	594	13.9	632	16.5	669	19.1	706	21.9
30000	1218	505	7.34	539	9.66	573	12.1	606	14.7	640	17.5	673	20.4	706	23.4	738	26.4
35000	1422	578	10.7	608	13.4	637	16.1	666	19.0	694	22.0	723	25.1	752	28.4	781	31.8
40000	1625	652	15.0	679	18.1	705	21.2	730	24.3	756	27.6	780	31.0	805	34.5	830	38.1
45000	1828	727	20.6	751	23.9	775	27.5	798	30.9	820	34.4	843	38.1	865	41.8	887	45.7
50000	2031	803	27.4	825	31.0	846	34.9	867	38.8	888	42.6	908	46.5	928	50.6	949	54.7
55000	2234	879	35.6	899	39.6	919	43.7	938	48.0	957	52.3	976	56.5	994	60.7	1013	65.2
60000	2437	955	45.4	973	49.7	992	54.1	1010	58.7	1028	63.5	1045	68.2	1062	72.7	1079	77.3
65000	2640	1032	57.0	1049	61.6	1065	66.3	1082	71.1	1099	76.2	1115	81.4	1131	86.5	1147	91.4
70000	2843	1109	70.4	1124	75.3	1140	80.3	1156	85.5	1171	90.8	1187	96.3	1202	102	1217	107
75000	3046	1186	85.8	1200	91.1	1215	96.4	1229	102	1244	107	1259	113	1273	119	1287	125
CFM	OV FPM	5"		6"		7"		8"		9"		10"		12"		14"	
		RPM	BHP	RPM	BHP	RPM	BHP	RPM	BHP	RPM	BHP	RPM	BHP	RPM	BHP	RPM	BHP
		33000	1340	821	36.3	877	43.3	933	50.6								
36000	1462	845	40.1	898	47.5	950	55.1	1001	63.0								
39000	1584	871	44.2	922	52.0	971	60.0	1019	68.2	1066	76.7						
42000	1706	900	48.7	948	56.9	995	65.3	1041	73.9	1085	82.7	1129	91.8				
45000	1828	931	53.7	976	62.1	1021	70.9	1064	80.0	1107	89.2	1149	98.6	1231	118		
48000	1950	965	59.2	1007	67.9	1049	77.0	1090	86.4	1131	96.1	1171	106	1250	126	1327	147
51000	2071	1000	65.3	1039	74.3	1079	83.6	1118	93.3	1157	103	1196	114	1271	135	1344	156
54000	2193	1037	71.9	1073	81.2	1110	90.8	1148	101	1185	111	1222	122	1294	144	1365	166
57000	2315	1075	79.2	1109	88.8	1144	98.6	1179	109	1215	119	1250	130	1320	153	1388	176
60000	2437	1113	87.0	1146	97.0	1179	107	1212	118	1246	128	1279	140	1346	163	1412	187
63000	2559	1152	95.4	1184	106	1216	116	1247	127	1278	138	1310	150	1374	173		
66000	2681	1191	105	1223	115	1253	126	1283	137	1313	149	1343	160	1404	185		
69000	2802	1232	114	1262	125	1291	137	1320	148	1348	160	1377	172				
72000	2924	1273	125	1301	136	1330	148	1358	160	1385	172	1412	184				

Performance shown is for installation Type D: ducted inlet/ducted outlet. Power rating (BHP) does not include drive losses. Performance data is based on standard air conditions (0.075 #/ft.3). Performance ratings do not include the effects of appurtenances in the airstream. **MOST EFFICIENT FAN SELECTION APPEARS IN BOLD PRINT.** To complete model code, add arrangement, class of construction, material code, motor enclosure code, motor horsepower code and motor speed code. Refer to page 2 for more information.



Options and Accessories

Guards

Inlet and outlet guards are available for In-Line Centrifugal Fans. OSHA style, steel construction.



Belt Guard

Covers motor sheave and belts outside fan housing.

Combination Motor Cover and Belt Guard

Designed to fit belt drive in-line centrifugal fans. Covers are vented. Specify horizontal or vertical mounting.



Combination Drive Guard and Weather Cover

Covers motor and shaft sheaves as well as belts. Combines guarding of the drive as well as protection from the weather.

CAUTION: The drive assembly of the periphery of the wheel of a fan less than seven (7) feet above the floor or working level must be guarded to be in accordance with OSHA regulations.

V-Belt Drives

Constant speed (fixed pitch) or adjustable speed (variable pitch) oil, heat, and static resistant type V-Belt Drives, oversized for long life and continuous duty as standard, are available upon request.

Disconnect Switch

On-off switch mounted to the unit to provide safety during maintenance.

Drain

Standard pipe coupling, welded to the housing. Female pipe has threaded plug. Highly recommended for vertical airflow-up applications.

Inspection Door

Allows periodic visual inspection of wheel. Bolted and gasketed for tight seal. A hinged, quick release type is also available for class I only.



Prefabricated Curbs

Heavy gauge galvanized steel roof curbs, 8" or 12" high. Curbs feature a built in cant strip, welded seam construction.

Mounting Feet

Bolted to the inlet and discharge flanges, mounting feet allow positioning of the fan on the floor, ceiling, wall or platform. Can be used with vibration isolators.

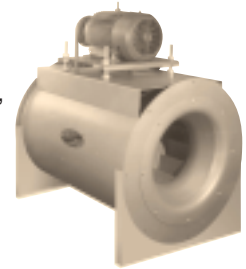

Ceiling Suspension

For Horizontal Mounting:
Sizes 12" to 18" – use inverted mounting feet.
Sizes 22" to 49" – use horizontal mounting brackets.

Vertical Mounting Brackets

Four welded brackets for floor mounting or ceiling suspension.

Vibration Isolators

Rubber-in-shear or spring type isolators available for floor mount or ceiling suspension on all models.

Companion Flanges

Drilled to fit the flanges of the fan; allows easy installation.



Lifting Lugs

Facilitates Installation.

Arrangement 1 Sub-Base

Common structural support for Arrangement 1 fan and motor. Specify motor frame size and mounting position (see page 4). Vibration isolators, belt guards, and motor covers are available for Arrangement 1 with sub-base construction.

Sound Muffler

Attenuator for inlet or outlet of fan, reduces sound up to 50%. Maximum velocity 3000 FPM velocity. Contact Factory for details.



Inlet and Outlet Cones

Fabricated cones for duct transitions and/or static pressure regain.

Inlet Control Damper

Dampers are mounted on the blower's drilled inlet flange to both increase the efficiency of the system and permit control of air volume. Standard construction limits these dampers to 7" maximum static pressures and 3000 FPM velocity. For more demanding conditions please contact the factory.

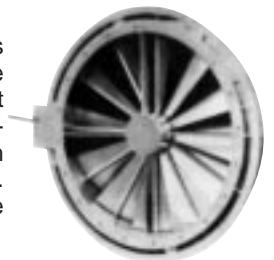

SAFETY ACCESSORIES, APPLICATION AND USE WARNING

The safe application and use of equipment supplied by Hartzell Fan, Inc. is the responsibility of the installer, the user, the owner, and the employer. Since the application and use of its equipment can vary greatly, Hartzell Fan, Inc. offers various product types, optional safety accessories, and sound performance data per laboratory tests. Hartzell Fan, Inc. sells its equipment with and without safety accessories, and accordingly, it can supply such safety accessories only upon receipt of an order. The need for safety accessories will frequently depend upon the type of system, fan location and operating procedures being employed. The proper protective safety accessories to meet company standards, local codes, and the requirements of the Occupation Safety and Health Act must be determined by the user since safety requirements vary depending on the location and use of the equipment. If applicable local conditions, standards, codes or OSHA rules require the addition of the safety accessories, the user should specify and obtain the required safety accessories from Hartzell Fan, Inc. and should not allow the operation of the equipment without them. Owners, employers, users and installers should read "RECOMMENDED SAFETY PRACTICES FOR USERS AND INSTALLERS OF INDUSTRIAL AND COMMERCIAL FANS" published by the Air Movement and Control Association International, Inc., 30 West University Drive, Arlington Heights, Illinois 60004. A copy of this publication is enclosed with each fan shipped from Hartzell Fan, Inc., and is available upon request at Hartzell's office in Piqua, Ohio 45356

Please contact Hartzell Fan, Inc. or your local Hartzell representative for more information on product types, safety accessories, and sound performance estimates. Remember, the selection of safety accessories and the safe application and use of equipment supplied by Hartzell Fan, Inc. is your responsibility.



General Construction Options

Spark Resistant Construction

For safely handling fumes and vapors, Hartzell offers three types of spark resistant construction. Types A, B, and C as outlined in AMCA Standard 99-0401-86.

Type A – All aluminum fan housing, inlet cone and wheel with a ground and polished steel shaft covered with an aluminum sleeve. Inner drum sealed with covers and gaskets. Temperature limitation of 180°F. Material Code AA.

Type B – Aluminum wheel and aluminum sleeve on the shaft where the shaft passes through the housing. Inner drum sealed with covers and gaskets. Temperature limitation of 180°F. Material Code AB.

Type C – Aluminum inlet cone and aluminum sleeve on the shaft where the shaft passes through the housing. Inner drum sealed with covers and gaskets. Temperature limitation of 180°F. Material Code AC.

NOTES: No bearings, drive components, or electrical devices shall be placed in the air or gas stream. The user shall electrically ground all fan parts.

The use of the above standard in no way implies a guarantee of safety for any level of spark resistance. Spark resistant construction also does not protect against any airstream material that may be present in a system which might cause ignition of explosive gases.

Protective Coatings

An epoxy coating is available for mildly corrosive atmospheres. The finish is chemical, moisture and abrasion resistant, providing a very tough and durable coating. Surfaces are pre treated prior to coating. Finish air dries to 6 mils. Temperatures range up to 180°F. Inorganic zinc coating is also available. This finish is a very hard coating with exceptional abrasion resistance. Offers excellent weathering characteristics and resistance to alcohols, solvents, and petroleum products. Also, resistant to temperatures up to 180°F. Surfaces are sandblasted prior to application. Finish air dries to 21/2 mil thickness.

Fiberglass Fans

Where extreme corrosive fumes are encountered, Hartzell Fiberglass In-Line Centrifugal Fans, Series 40, give unsurpassed resistance to a wide variety of corrosive elements at a cost substantially below that of corrosive resistant metals. Size range of 12" to 60" wheel diameter. For complete details on Hartzell Fiberglass In-Line Centrifugal Fans, See Bulletin A-131.



Fiberglass In-Line Centrifugal Fan Series 40

Power Roof Ventilator

The belt driven in-line centrifugal fan can be mounted as a roof exhausted. Together with a stack cap and curb panel for mounting the three components combine to provide a roof unit for exhaust applications. Stack cap has back draft dampers, providing weather-tight closure for vertical air discharge.

A fusible link can be furnished as an option. This is a spring-operated, positive lid opener for power roof ventilators. When the

temperature at the stack cap lids exceeds 165° F., the fusible link allows the spring – operated lid opener to lock the stack cap lids in upright position. Provides gravity ventilation in case electricity to the ventilator is interrupted during a fire.

To prevent lid flutter when positive pressure exists in a building, magnetic latches can be furnished as an option.

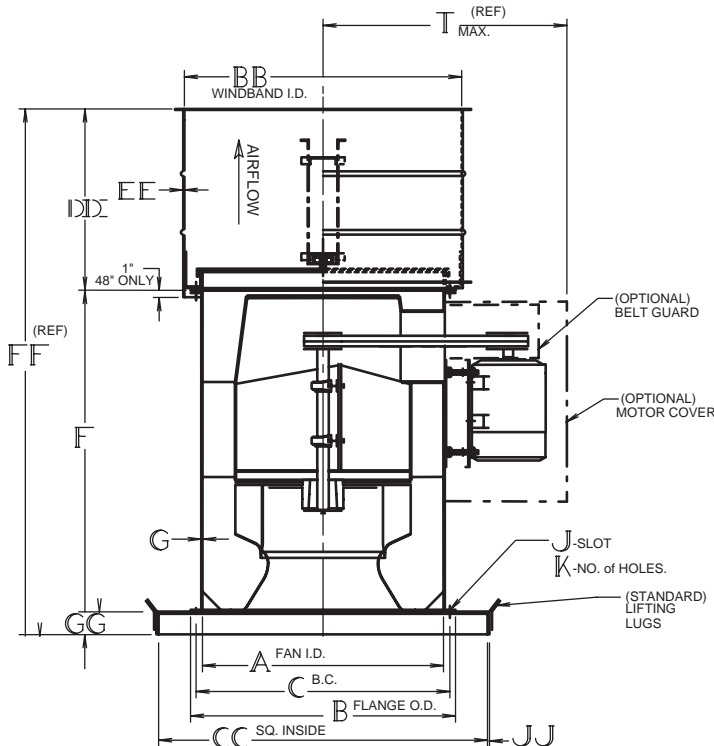

CFM Limitations for Damper Lids Operation and Principal Dimensions (Inches)

Size	Without Outlet Transition *					
	Min. ¹	Max. ²	A	BB	CC	FF
12	1,930	4,750	16 ^{13/16}	22	26	43 ^{1/2}
15	2,980	7,335	21 ^{1/16}	26	32	51 ^{1/2}
18	4,255	10,475	25 ^{3/8}	30	36	59 ^{1/2}
22	6,595	16,235	31	36	42	67 ^{1/2}
24	7,490	16,435	33 ^{3/4}	41	44	73
27	9,445	26,250	37 ^{7/8}	44	48	80
30	11,630	28,630	41 ^{1/8}	48	51	86
33	14,040	34,560	45 ^{1/4}	52	55	93
36	16,680	41,055	49 ^{3/8}	56	60	100
40	21,255	52,315	55 ^{3/16}	62	65	110
44	26,170	64,410	51	68	71	120
49	31,590	77,765	57 ^{2/16}	75	71	117

*CFM limitations can be increased or decreased with installation of an outlet transition. Contact factory for additional information.

¹Minimum CFM to open lids. ²Maximum CFM to prevent lid damage. Guy wire bracing must be provided by customer when necessary.

Dimensions and specifications are subject to change. Certified prints are available.



Hartzell Warranty

LIMITED WARRANTIES

Hartzell represents to Buyer that any goods to be delivered hereunder will be produced in compliance with the requirements of the Fair Labor Standards Act of 1938 as amended.

Hartzell also warrants to Buyer its goods to be free from defects in workmanship and material under normal use and service for one (1) year after tender of delivery by Hartzell, plus six (6) months allowance for shipment to approved stocking dealers & distributors. No warranty extends to future performance of goods and any claims for breach of warranty or otherwise accrues upon tender of delivery.

The foregoing constitute Hartzell's sole and exclusive warranties in lieu of all other warranties, whether written, oral, express, implied or statutory.

LIMITATION OF LIABILITY FOR BREACH OF WARRANTY

Hartzell's obligation for any breach of warranty is limited to repairing or replacing, at its option, without cost to Buyer at its factory any goods which shall, within such a warranty period, be returned to it with transportation charges prepaid, and which its examination shall disclose to its satisfaction to have been defective. Any request for repair or replacement should be directed to Hartzell Fan, Inc., P.O. Box 919, Piqua, Ohio 45356. Hartzell will not pay for any repairs made outside its factory without its prior written consent. This does not apply to any such Hartzell goods which have failed as a result of faulty installation or abuse, or incorrect electrical connections or alterations, made by others, or use under abnormal operating conditions or misapplication of the goods.

LIMITATION OF LIABILITY

To the extent the above limitation of liability for breach of warranty is not applicable, the liability of Hartzell on any claim of any kind, including negligence, for any loss or damage arising out of or connected with, or resulting from the sale and purchase of the goods or services covered by these Terms and Conditions of Sale or from the performance or breach of any contract pertaining to such sale or purchase or from the design manufacture, sale, delivery, resale, installation, technical direction installation, inspection repair, operation or use of any goods or services covered by these Terms and Conditions shall, in no case exceed the price allocable to the goods or services which gave rise to the claim and shall terminate one year after tender of delivery of said goods or services.

In no event whether as a result of breach of contract, or warranty or alleged negligence, defects incorrect advice or other causes, shall Hartzell be liable for special or consequential damages, including, but not limited to, loss of profits or revenue, loss of use of the equipment or any associated equipment, cost of substitute equipment, facilities or services, down time costs, or claims of customers of the Buyer for such damages. Hartzell neither assumes nor authorizes any person to assume for it any other liability in connection with the sale of its goods or services.

NO IMPLIED WARRANTIES OF MERCHANTABILITY OR FITNESS.

HARTZELL DOES NOT WARRANT THAT SAID GOODS ARE OF MERCHANTABLE QUALITY OR THAT THEY ARE FIT FOR ANY PARTICULAR PURPOSE. THERE IS NO IMPLIED WARRANTY OF MERCHANTABILITY AND THERE IS NO IMPLIED WARRANTY OF FITNESS.



Propeller Fans

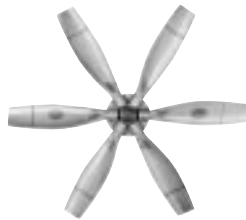

Cooling Tower & Heat Exchanger Fans

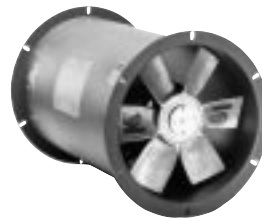

Duct Fans



Duct Axial Fans



Vaneaxial Blowers



Cool Blast & Utility Fans

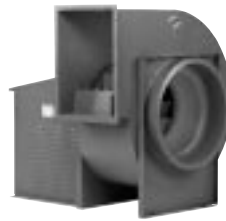

Steel Centrifugal Blowers



Roof Ventilators - Steel & Fiberglass



Heating Equipment - Gas & Steam



Fiberglass Axial Flow Fans



Fiberglass Centrifugal Blowers



Marine - Mine Duty Blowers

Hartzell Fan, Inc., Piqua, Ohio 45356 • Plants in Piqua, Ohio and Portland, Indiana.